



INVITATION FOR BID
IFB No: PAG-CIP-024-003

PROJECT TITLE:
WAREHOUSE 1 ROOF VENT REPLACEMENT

PORT AUTHORITY OF GUAM
1026 Cabras Highway
Piti, Guam 96915

RORY J. RESPICIO
General Manager

MAY 2024

AD BLOCK

VOLUME 1
GENERAL INFORMATION AND INSTRUCTIONS
TO BIDDERS

GENERAL INFORMATION

I. INTRODUCTION

The Jose D. Leon Guerrero Commercial Port or Port Authority of Guam (PAG), hereinafter referred to as PAG, is inviting firms to participate in the Invitation for Bid (IFB), for **IFB-PAG-CIP-024-003 WAREHOUSE 1 ROOF VENT REPLACEMENT PROJECT**.

PROJECT LOCATION:

This project is located at Jose D. Leon Guerrero Commercial Port Warehouse 1 Building Piti, Guam.

PROJECT DESCRIPTION:

The Port Authority of Guam is interested in soliciting an Invitation for Bid for the Warehouse 1 Roof Vent Replacement Project. Several roof vents were severely damaged or lost during Typhoon Mawar. Warehouse 1 has a total of fifteen (15) roof vent openings that are located at the center of each bay. Many of the roof vents are currently missing. This project will result in the replacement of all damaged and missing roof vents, to include the repair of the concrete curb the roof vents are mounted to. This project is funded in part by the Public Assistance (PA) Grant Program under the Federal Emergency Management Agency (FEMA) and is subject to the requirements stated in the grant award terms and conditions.

All work shall comply with applicable codes such as the International Building Code (IBC) 2009, Occupational Safety and Health Association (OSHA), National Electrical Code (NEC), American Concrete Institute (ACI), American Society for Testing & Materials (ASTM), and the Underwriter Labor (UL).

II. INSTRUCTIONS TO BIDDERS:

These instructions to bidders are intended to provide guidance in the preparation of bid proposals. Please note that the act of submitting a bid to this IFB, constitutes an acceptance on the part of the Bidder that they have read each and every provision; and thus, agree to all terms and conditions contained within this bid, as well as, that they have read and understood all of the bid documents, including all information contained within the appendices.

1. PRE-BID CONFERENCE, INQUIRIES, AND COMMUNICATIONS

A **PRE-BID CONFERENCE** is scheduled on **TUESDAY, JUNE 11, 2024 at 10:00am Chamorro Standard Time (Guam Time)** at the PAG Board of Directors' Conference Room, 1st floor, PAG Administration Bldg. All prospective bidders are encouraged to attend. **SITE VISIT of the proposed project will be immediately following the pre-bid conference.** To enter the Port's compound a valid ID is required 24 hours prior to the site visit. You will need a hard hat, safety vest, closed-toe shoes, raincoat (dependent on weather), writing material, camera, and measuring tools as the Port will not provide these for you.

All **QUESTIONS AND CONCERNS (Q&C)** (inquiries, clarifications, or questions) must be submitted in writing on **WEDNESDAY, JUNE 12, 2024**, no later than **4:00 p.m. Chamorro Standard Time (Guam Time)**. Q&C shall be submitted to the attention of Mr. Rory J. Respicio, PAG General Manager, and may be sent via email to rjrespicio@portofguam.com. Please send a copy to Ms. Annie LG. Sablan – Acting Procurement & Supply Manager, at algsablan@portofguam.com. Port will respond in writing to all written inquiries and/or clarifications via an addendum to this IFB. All formal communications shall be issued through the Addendum process only and shall be distributed to all recognized registered bidders.

2. RECEIPT OF BID OFFERS

Bids will be received at the Procurement and Supply Division, 1ST Floor of the Port Authority of Guam (PAG) Administration Building on **FRIDAY, JUNE 21, 2024, no later than 3:00 P.M. Chamorro Standard Time (Guam Time)**. In response to this Invitation for Bid (IFB), interested parties shall submit bids in the format described in these bid documents and shall be addressed to Mr. Rory J. Respicio, General Manager, Port Authority of Guam, 1026 Cabras Highway, Suite 201, Piti, Guam 96915.

One (1) original, two (2) copies, and one (1) CD or USB containing an electronic file copy (in PDF format) of the complete bid proposal shall be enclosed in a sealed package or envelope, clearly labeled on the outside as **“INVITATION FOR BID - IFB-PAG-CIP-024-003 WAREHOUSE 1 ROOF VENT REPLACEMENT PROJECT”**. The package or envelope must be clearly labeled with the name of the Bidder.

All bid proposals submitted after the time and date set for a receipt as indicated above shall be considered Late Bids and will not be considered. Late bids will be returned “un-opened” to the bidder. Attention is called to the fact that bidders not only offer to assume the obligations and liabilities imposed upon the Contractor in the form of a contract but expressly make certain of the representations and warrants made therein. No effort is made to emphasize any particular provision of the contract, but bidders must familiarize themselves with every provision of the contract and its effect.

Prohibited Communication: Bidders shall conduct themselves with professional integrity and refrain from lobbying activities. During the procurement process (commencing with the issuance of this IFB and continuing until execution of a contract resulting from this solicitation or cancellation of the procurement), no employee, member, agent, advisor, or consultant of any Bidder shall have any communications, directly or indirectly, regarding this procurement with any representative of the Port, including their staff, advisors, contractors, or consultants involved with the procurement, except for communications expressly permitted by this IFB to the attention of the General Manager or the Procurement and Supply Manager. Any verified allegation that the Bidder or an employee, agent, advisor, consultant, or subcontractor of the Bidder engaged in such prohibited communications or attempted to unduly influence any part of the solicitation may be cause for Port to disqualify the Bidder from participating at the discretion of the Port.

Oral explanations or instructions should not be given, but if any are inadvertently or improperly given, no oral representations by any representative of PAG will be binding and any action taken by the Bidder based upon such oral advice or clarification will be at the sole risk of the Bidder.

3. IFB DOCUMENTS

IFB Documents or electronic copies of the IFB are available at no charge and can be obtained at the Procurement & Supply Office on the Port’s website at <https://portofguam.com/bids-and-rfps> or 1st floor of the Port Authority of Guam, Administration Building located at 1026 Cabras Highway, Suite 201, Piti, Guam 96915.

The IFB Documents are organized into five separate volumes, as follows:

- Volume 1** - General Information/Instruction to Bidders
- Volume 2** - General Conditions and Special Provisions
- Volume 3** - Required Forms and Affidavits
- Volume 4** - Sample Construction Agreement
- Performance and Payment Bond Form
- Volume 5** - Scope of Work, Bid Schedule, Photos and Drawings

4. MODIFICATIONS AND SOLICITATION AMENDMENT

Any amendment, modification or addendum issued by the PAG prior to the opening of the bids, for the purpose of changing the bid requirements, clarifying the meaning or changing any of the provisions of this IFB, shall be binding to the same extent as if written in the bid documents and will be deemed incorporated into the contract or not.

The PAG reserves the right to amend, supplement, cancel and/or reissue this bid in whole or in part at any time, when this action serves the best interest of the PAG. Any modification that are of a nature which requires material changes in quantities or prices to be bid or both, the date set for opening bids may be postponed by such number of days as in the opinion of the issuing officer. In such cases, the addendum will include an announcement of the new date for opening proposals/bids. Such revisions, if any, will be announced by an addendum or addenda to this invitation for bid and bidders shall acknowledge receipt of such addenda by signature, which is to be returned to the Procurement and Supply Office by fax or by email. Failure to acknowledge receipt of any addenda will result in rejection of bidders’ proposal/bid.

5. FAMILIARITY WITH LAWS

The bidder shall be familiar with all Federal (U.S.) and local laws, ordinances, rules and regulations of Guam that in any manner affect the work. Ignorance of law or on the part of the bidder will not relieve the bidder from responsibility.

6. PREPARATION AND SUBMISSION OF BID

The bidder must submit his bid on the forms furnished by the PAG. All blank spaces in the bid forms must be correctly filled in and the bidder must state the prices (both in words and numerals) for which he proposes to do each item of the work contemplated or furnish each item of the materials required. In case of conflict between words and numerals, the words, unless obviously incorrect, will govern. Erasures or other changes in a bid must be explained or noted over the signature of the bidder. Bids containing any conditions, omissions, unexplained erasures or alterations or items not called for in the proposal or irregularities of any kind may be rejected by the PAG as being incomplete.

All bids must give the full business address of the bidder and be signed by him with his usual signature. Bids by partnerships must furnish the full names of all partners and must be signed in the name of the partnership by one of the members of the partnership or by an authorized representative followed by the signature and designation of the person signing. Bids by corporations must be signed with the legal name of the corporation, followed by the name of the State of incorporation and by the signature and designation of the president, secretary, or other person authorized to bind it in the matter. The name of each person signing shall also be typed or printed below the signature. A bid by a person who affixes to his signature the word "president", (agent or other designation, without disclosing his principal), may be held to the bid of the individual signing. When requested by the Owner, satisfactory evidence of the authority of the officer signing in behalf of the corporation shall be furnished.

The PAG is not liable for any costs incurred by the bidder in connection with the preparation of this solicitation. By submitting a bid, the bidder specifically waives the right against the PAG for any expenses incurred in his bid preparation. Submitted bids become the property of the PAG. Bidder's request for the return of specific proprietary materials may be honored.

7. TRADE SECRETS AND PROPRIETARY DATA

Bidders may request to have certain portions of their bid submittals designated as trade secrets or proprietary data. PAG will examine such request to determine the validity of any requests for nondisclosure of trade secrets and other proprietary data identified in the request. If the PAG and bidder are unable to agree as to the disclosure of certain portions of the bidder's bid will be disclosed and that, unless the bidder withdraw its bid or protests under 5 GCA Article 9 (Legal and Contractual Remedies) of the Guam Procurement Act, the information may be so disclosed. The bids shall be opened to public inspections subject to any continuing prohibition on the confidential data.

8. WITHDRAWAL OF BIDS

Bids may be withdrawn on written or telegraphic request received from bidders prior to the time and date set for bid opening. Negligence on the part of the bidder in preparing the bid confers no right to the withdrawal of the bid after it has been opened.

9. BID SECURITY, PERFORMANCE, AND PAYMENT BOND

Each bid must be accompanied by a deposit in the amount of not less than fifteen percent (15%) of the highest bid price for which award can be made. Such deposit may be in the form of a bid bond, cashier's check, or certified check made payable to the Port Authority of Guam. Should the successful bidder fail or refuse to execute and deliver the contract and performance and payment bonds required within ten (10) working days after acceptance of his bid by the Government, he shall forfeit to the Government of Guam as liquidated damages for such failure or refusal, the security deposited with his bid.

10. BUSINESS LICENSES

Bidders are reminded that all firms proposing and/or bidding on Government of Guam contracts must be fully licensed to do business in Guam at the time of submission of bids. Bidders must submit a copy of a current Contractor's License for constructions services issued by the Guam Contractor's License Board in conformance with Public Law 14-51. Failure to submit a conforming Contractor's License shall result in the bid being declared non-responsive, whereby bid will be rejected.

Additionally, professional services firms as sub-consultants of Prime Bidder, are required to have a Certificate of Authorization (COA) through the Board of Professional Engineers, Architects, and Land Surveyors, Guam (PEALS) at the time of submission of bids.

11. RIGHT TO ACCEPT AND REJECT BIDS

The PAG reserves the unqualified right, in its sole and absolute discretion, to reject any and all bids, or to accept that bid or combination of bids, if any, or waive informalities and minor irregularities in the bids, including the sole right to determine what constitutes irregularities in the bids which in its sole and absolute judgment will under all circumstances best serve the Government's interests. In the event that the successful bidder fails to execute the contract upon his part or to furnish a satisfactory performance and payment bond, the Government, after declaring forfeited the security deposit of such bidder, reserves the option to accept the bid of any other bidder within ten (10) calendar days from such default, in which case such acceptance shall have the same effect as to such bidder as though he was the original successful bidder.

12. METHOD OF AWARD

Pursuant to 5 GCA §5211(g) of the Guam Procurement Act, the contract is to be awarded to the **lowest responsive, responsible bidder whose bid meets the requirements and criteria set forth in this Invitation for Bid.**

The award shall be made in accordance to with following conditions: Bidding procedure involving only a basic bid: If the total of the basic bid items is within the number funds available to finance the project, then a contract award will be made to that bidder submitting the lowest responsive and responsible basic bid.

13. COMPETENCY OF BIDDERS

The Port will require bidders to present satisfactory evidence that he has sufficient experience and past performance and is fully prepared with the necessary capital, material, machinery, and skilled workmen and supervisory staff to carry out the contract satisfactorily. The information is required for the Prime Contractor and each subcontractor if any.

The purpose of this requirement is to provide the Port with a basis for determining the Prime Contractor and its subcontractors' financial and technical capability for undertaking this project which shall deem the Bidder as responsive and responsible. The Port is not interested in a voluminous description of all prior contracts undertaken, but rather a concise, thorough description of past experience relevant to this project.

Accordingly, in the Port's determination of a responsive and responsible bidder, the Contractor and its sub-contractors must submit for review the following documents and statements:

- a. Organizational Structure identifying the Prime Contractor and all its sub-contractors
- b. Experience of key staff or firm on similar work.
- c. Past performance of firm or key (to be assigned to this project) staff in accomplishing government projects or other client projects of this nature in the agreed time. Bidders and their sub-contractors must include a listing of past performances of key personnel with similar projects;
- d. Availability of plant, machinery, and other equipment necessary for work.
- e. References who can attest to the quality of work on past or ongoing projects being performed for Local and Federal Governments and other organizations/clients.
- f. References who can attest to Contractor's diligence in carrying out responsibility.
- g. References who can attest to, or documents that can illustrate, a record of good Owner-Contractor relationship.
- h. Statement about the previous record of bids qualification, for example no loss of bid bonds and/or no rejections following responsibility checks.
- i. Record of the past performance of government contracts including a record of default and nonpayment of obligations.
- j. Possession of Government of Guam appropriate contractor's license

Any bidder, who at the time of bidding has been determined by the PAG or the Dept. of Public Works to be liable to pay liquidated damages for delay in completion of the last two projects contracted with any Government of Guam projects, will be automatically rejected.

III. COMPLIANCE WITH LAWS AND MANDATORY FORMS FOR SUBMITTAL

1. DISCLOSURE OF MAJOR SHAREHOLDERS:

As a condition of bidding, any partnership, sole proprietorship or corporation doing business with the Port Authority of Guam shall submit an affidavit executed under oath that lists the name and address of any person who has held more than ten percent (10%) of the outstanding interest or shares in said partnership, sole proprietorship or corporation at any time during the twelve (12)-month period immediately preceding submission of a bid. The affidavit shall contain the number of shares or the percentage of all assets of such partnership, sole proprietorship or corporation which have been held by each such person during the twelve (12)-month period. In addition, the affidavit shall contain the name and address of any person who has received or who is or may become entitled to receive a commission, gratuity or other compensation for procuring or assisting in obtaining business related to the bid for the bidder and shall also contain the amounts of any such actual or potential commission, gratuity or other compensation. The affidavit shall be open and available to the public for inspection and copying. Failure by any bidder to submit the **Affidavit Disclosing Ownership and Commissions - AG Form 002**, shall result in the disqualification of his bid.

2. NON-COLLUSION AFFIDAVIT

Each person submitting a bid for any portion of the work covered by the bid documents shall execute an affidavit, in the form provided with the bid, to the effect that he has not colluded with any other person, firm or corporation in regards to any bid submitted. Such affidavit shall be attached to the bid. Failure by any bidder to submit the **Affidavit Re Non-Collusion - AG Form 003**, shall result in the disqualification of his bid.

3. INDEPENDENT PRICE DETERMINATION

Every solicitation shall provide that by submitting a bid or offer, the bidder or offeror certifies that the price submitted was independently arrived at without collusion.

4. REPRESENTATION REGARDING GRATUITIES AND KICKBACKS

The bidder, offeror or contractor represents that it has not violated, is not violating, and promises that it will not violate the prohibition against gratuities and kickbacks set forth in 2 GAR, Div. 4, §11107, 5 GCA §5631 (a) and 2 GAR, Div. 4, §11108 of the Guam Procurement Regulations. Failure by any bidder to submit the **Affidavit Re No Gratuities or Kickbacks- AG Form 004**, shall result in the disqualification of his bid.

5. PROHIBITION AGAINST GRATUITIES, KICKBACKS AND FAVORS

5GCA Government Operations Chapter 5 Guam Procurement Law § 5630. Gratuities Kickbacks, and Favors

(a) Gratuities. It shall be a breach of ethical standards for any person to offer, give or agree to give any employee or former employee, or for any employee or former employee to solicit, demand, accept or agree to accept from another person, a gratuity or an offer of employment in connection with any decision, approval, disapproval, recommendation, preparation of any part of a program requirement or a purchase request, influencing the content of any specification or procurement standard, rendering of advice, investigation, auditing, or in any other advisory capacity in any proceeding or application, request for ruling, determination, claim or controversy, or other particular matter, pertaining to any program requirement or a contract or subcontract; or to any solicitation or proposal therefor.

(b) Kickbacks. It shall be a breach of ethical standards for any payment, gratuity or offer of employment to be made by or on behalf of a subcontractor under a contract to the prime contractor or higher tier subcontractor or any person associated therewith, as an inducement for the award of a subcontract or order.

(c) Contract Clause. The prohibition against gratuities, kickbacks and favors to Guam prescribed in this Section shall be conspicuously set forth in every contract and solicitation therefore.

(d) Favors to Guam. For purposes of this Section, a favor is anything, including raffle tickets, of more than de minimis value and whether intended for the personal enjoyment of the receiver or for the department or organization in which they are employed or for any person, association, club or organization associated therewith or sponsored thereby. It shall be a breach of ethical standards for any person who is or may become a contractor, a subcontractor under a contract to the prime contractor or higher tier contractor, or any person associated therewith, to offer, give or agree to give any employee or agent of Guam or for any employee or agent of Guam to solicit or accept from any such person or entity or agent thereof, a favor or gratuity on behalf of Guam whether or not such favor or gratuity may be considered a reimbursable expense of Guam, during the pendency of any matter related to procurement, including contract performance warranty periods.

6. REPRESENTATION REGARDING ETHICAL STANDARDS FOR GOVERNMENT EMPLOYEES AND FORMER GOVERNMENT EMPLOYEES

The bidder, offeror or contractor represents that it has not knowingly influenced and promises that it will not knowingly influence a government employee to breach any of the ethical standards set forth in 5 GCA, §5601 *et seq.* (Ethics in Public Contracting) of the Guam Procurement Act. Failure by any bidder to submit the **Affidavit Re Ethical Standards - AG Form 005**, shall result in the disqualification of his bid.

7. COMPLIANCE WITH WAGE LAWS

The bidder who is awarded a contract shall pay employees, at a minimum, in accordance with the Wage Determination for Guam and the Northern Mariana Islands issued and promulgated by the U.S. Department of Labor for such labor as is employed in the direct delivery of contract deliverables to the Port. In the event of a renewal of a contract, the Wage Determination promulgated by the U.S. Department of Labor on a date most recent to the renewal date of the contract shall apply to that renewal contract. In addition to the applicable Wage Determination, the contract shall contain provisions mandating health and similar benefits for employees, such benefits having a minimum value as detailed in the Wage Determination promulgated by the U.S. Department of Labor, and shall contain provision guaranteeing a minimum of ten (10) paid holidays per annum for each employee.

The bidder is required to execute and submit the **Declaration Re Compliance with U.S. DOL Wage Determination- AG Form 006**. Failure to submit such form shall result in the disqualification of his bid.

8. PROHIBITION AGAINST CONTINGENT FEES

The bidder, offeror or contractor represents that it has not retained a person to solicit or secure a territorial contract upon an agreement or understanding for a commission, percentage, brokerage, or contingent fee, except for retention of bona fide employees or bona fide established commercial selling agencies for the purpose of securing business. Failure by any bidder to submit the **Affidavit Re Contingent Fees - AG Form 007**, shall result in the disqualification of his bid.

9. ETHICAL STANDARD

It shall be a breach of ethical standards for an Offeror to knowingly influence a government employee to breach any of the ethical standards set forth in 5 GCA Chapter 5 Article 11 (Ethics in Public Contracting) of the Guam Procurement Law and in Article 11 of the government of Guam Procurement Regulations.

10. LOCAL PROCUREMENT POLICY

No specification, term, condition, or qualification of this RFP shall exclude any Offeror from consideration on the basis of Guam-only experience provided that the experience of such Offeror is otherwise responsive to the solicitation, in accordance with the requirements of 5 GCA § 5008(e).

11. POLICY IN FAVOR OF SERVICE-DISABLED VETERAN OWNED BUSINESSES

This procurement shall be conducted in accordance with the terms and conditions of 5 GCA §§ 5011 and 5012

12. PRODUCTS MANUFACTURED FROM RECYCLED GLASS

Pursuant to Title 5, GCA Section 5218, any individual or company submitting a response to this solicitation shall include the purchase of available recycled glass pulverized on Guam or appropriate products manufactured therein. The contract awarded under this solicitation shall determine the suitable percentage of recycled glass to be used on the project and, as a condition of the contract award, shall require the Contractor to identify and certify in writing the percentage of recycled glass contained in the material offered.

13. APPRENTICE TRAINING PROGRAM

Pursuant to Executive Order No. 2000-10, the contractor shall employ at least one (1) apprentice for every ten (10) workers for the duration of the project, and not less than one (1) apprentice per project. This requirement may be waived only if the Department of Public Works and the Guam Community College both certify that no apprentice is available.

The Executive Order applies to all public works construction projects such as the erection, maintenance, rehabilitation, repair, or demolition of any public building, roadway, or any public facility as defined in §50106 of Title 5, GCA, and applies to all departments and agencies within the government of Guam. It also applies only to projects over One Hundred Thousand Dollars (\$100,000.00).

The Director of the Department of Public Works shall monitor the compliance with this Executive Order and enforce and exercise authority to achieve the objectives of the Executive Order and shall report to the Guam Community College on a quarterly basis, the impact of this program.

The Guam Department of Labor shall inform all employers applying for H-2 alien labor certification that to qualify for government of Guam construction projects, all conditions of Executive Order No. 2000-10 shall be met.

14. Restriction Against Contractors Employing Convicted Sex Offenders from Working at Government of Guam Venues.
(Subsection 5253 of Title 5 Guam Code Annotated)

- a. No person convicted of a sex offense under the provisions of Chapter 25 of Title 9 Guam Code Annotated, or an offense as defined in Article 2 of Chapter 28, Title 9 GCA in Guam, or an offense in any jurisdiction which includes, at a minimum, all of the elements of said offenses, or who is listed on the Sex Offender Registry, and who is employed by a business contracted to perform services for an agency or instrumentality of the government of Guam, shall work for his employer on the property of the government of Guam other than a public highway.
- b. All contracts for services to agencies listed herein shall include the following provisions: (1) warranties that no person providing services on behalf of the contractor has been convicted of a sex offense under the provisions of Chapter 25 of Title 9 of GCA or an offense as defined in Article 2 of Chapter 28, Title 9 GCA, or an offense in another jurisdiction with, at a minimum, the same elements as such offenses, or who is listed on the Sex Offender Registry; and (2) that if any person providing services on behalf of the contractor is convicted of a sex offense under the provisions of Chapter 25 of Title 9 GCA or an offense as defined in Article 2 of Chapter 28, Title 9 GCA or an offense in another jurisdiction with, at a minimum, the same elements as such offenses, or is listed on the Sex Offender Registry, that such person will be immediately removed from working at said agency and that the administrator of said agency be informed of such within twenty-four (24) hours of such conviction.
- c. Duties of the General Services Agency or Procurement Administrators. All contracts, bids, or Request for Proposals shall state all the conditions in §5253(b).
- d. Any contractor found in violation of §5253(b), after notice from the contracting authority of such violation, shall, within twenty-four (24) hours, take corrective action and shall report such action to the contracting authority. Failure to take corrective action within the stipulated period may result in the temporary suspension of the contract at the discretion of the contracting authority.
- e. Subject to the provisions of 12 GCA §10402 (Public Law 29-23), the contract will contain performance reviews at least annually, and provisions for contract termination and penalty based upon such review.

15. DOCUMENTS EXECUTED OUTSIDE GUAM

The Power of Attorney, affidavits, bonds, and/or any documents defining the constitution of the joint venture, consortium, company or firm, if executed outside Guam, whether required to be submitted with the proposals or upon award of the contract, must be authenticated by a Notary Public or other official duly authorized by law in the jurisdiction where they are authorized to witness sworn statements.

16. EQUAL EMPLOYMENT OPPORTUNITY

In compliance with the 14th Amendment to the Constitution, Section 5 (Bill of Rights) and 9(a) (Merit System), and federal laws; Title VI and VII of the Civil Rights Act.; the Civil Rights Act of 1991; Title I of the American Disabilities Act; the Equal Pay Act; the Age Discrimination in Employment Act; Section 504 of the Vocational Rehabilitation Act; Title IX of the Education Amendments of 1972; other pertinent federal laws and Guam laws; Title 4 of the Guam Code Annotated; Title 17, Chapter 2 of the Guam Code Annotated; Public law 14-28, Section 5; Public Law 15-17; Public Law 28-68; Public law 28-112 and other pertinent laws, it is the intent of the Government of Guam, hereinafter the Government:

- A. To provide equal employment opportunity for all applicants and employees to compete and be considered for jobs on the basis of merit and ability to perform, and to prohibit discrimination in any aspect, term, condition or privilege of employment on the basis of race, religion, color, sex, including sexual harassment and orientation, national origin, age, physical or mental disability, marital status, or political affiliation and retaliation. *Such discrimination against any person in recruitment, examination, appointment, training, promotion, retention, discipline, or any other aspect of personnel administration is prohibited.
 - *Except where specific factors legally constitute a bona fide occupational qualification or in the case of specifically funded programs to facilitate employment of disadvantaged persons, but only with the prior approval of the Equal Opportunity Administrator.*

- B. To carry out all government programs and activities in compliance with applicable Federal and Territorial laws and in such a manner that no person shall, on a basis of race, religion, color, sex, including sexual harassment and orientation, national origin, age, physical or mental disability, marital status, or political affiliation and retaliation be excluded from participation in, be denied the benefits of, or be subjected to discrimination with respect to any program or activities.

*** * * * * END OF GENERAL INFORMATION * * * * ***

VOLUME 2
GENERAL CONDITIONS AND SPECIAL PROVISIONS

GENERAL CONDITIONS

I. DEFINITIONS

1. Owner

The term "Owner" as used herein means the Port Authority of Guam, Cabras Hwy, Piti and shall include the Governor of Guam, and/or his authorized representatives.

2. Contracting Officer

The term "Contracting Officer" as used herein means the General Manager of the Port Authority of Guam and shall include his authorized representatives.

3. Engineer

The term "Engineer" as used herein means the Port Authority's Manager of CIP/Engineering and shall include his authorized representatives.

4. Contractor

The term "Contractor" as used herein means the party or parties who or which shall have duly entered into a contract with the Port Authority of Guam to perform the work herein contemplated or his or their authorized assignee.

5. Notice

The term "Notice" as used herein shall mean and include all written notice demands, instructions, claims, approvals and disapprovals required to obtain compliance with contract requirements. Any written notice by either party to the contract shall be sufficiently given if delivered to or at the last known business address of the person, firm, or corporation constituting the other party to the contract, or to his, their, or its duly authorized agent, representative, or officers, or when enclosed in a postage prepaid envelope addressed to such last known business address and deposited in a United States mail box. The Contractor must provide and maintain a post office address within Guam and file the same with the Contracting Officer.

6. Forms Enclosed

The copies of the Formal Contract and Bid Bond, enclosed herewith are incorporated in these General Conditions by reference and are made a part hereof to the same extent as though fully set forth herein.

II. CONSTRUCTION CONTRACT

1. Contract Documents

- a. The contract documents consist of the Formal Contract, the Technical Specifications, and Plans (Drawings) including all addenda and alterations made in the documents prior to their execution.
- b. The contract documents shall be signed by the Owner and Contractor in as many original counterparts as may be mutually agreed upon.
- c. Anything required by one of the contract documents shall be of like effect as if required by all the contract documents whether the other contract documents have the same requirement or not. In case of conflict between the contract documents, the technical specifications shall take precedence over the plans, and the Formal Contract shall be controlling over the plans and technical specifications. Any discrepancies between the Contract documents shall be called to the attention of the Contracting Officer before proceeding with work affected thereby.
- d. It will be conclusively presumed that the Contractor has read, examined and agreed to each and every term, conditions, provisions, covenant or agreement in the plans (drawings), technical specifications, bid forms, contract, and conditions related to the work to be carried on, said documents being on file in the Procurement Office, Port Authority of Guam; 1026 Cabras Hwy., Suite 201; Piti, Guam.

2. Drawings

- a. In case of differences between small scale and large-scale drawings, the large-scale drawings shall govern. Figured dimensions on the drawings shall be considered primary compared with measurements obtained through scaling of drawings. The Contractor shall verify all dimensions, and if any may be lacking, he shall call the attention thereto and be governed by the decision of the Contracting Officer.

- b. Where the word "similar" occurs on the drawings, it shall be interpreted in its general sense and not as meaning identical.
- c. The approval of shop and setting drawings will be general and shall not be construed (1) as permitting any departure from the contract requirements, (2) as relieving the Contractor of the responsibility for any error in details, dimensions and otherwise that may exist; (3) as approving departures from additional details or instructions previously furnished by the Contracting Officer.
- d. The Contractor will be furnished additional instructions and detail drawings as may be necessary to carry out the work included in the contract. The additional drawings and instructions thus supplied to the Contractor shall be consistent with the contract documents and true developments thereof, and shall be so prepared that they can be reasonably interpreted as a part thereof. The Contractor shall carry out the work in accordance with the additional detail drawings and instructions.

3. Contract Change Orders

- a. The Contracting Officer at any time, without notice to the sureties may, by written order designated or indicated to be a change order, may make any change in the work within the general scope of the contract, including but not limited to changes:
 - i. In the specifications (including drawings and designs);
 - ii. In the method or manner of performance of the work;
 - iii. In the Government-furnished facilities, equipment, materials, services for site; or
 - iv. Directing acceleration in the performance of the work.
- b. Any other written order (which terms as used in this paragraph (b) shall include direction, instructions, interpretations or determination from the Contracting Officer) which causes any such change, shall be treated as a change order under this clause, provided that the Contractor gives the Contracting Officer written notice stating the date, circumstances and source of the order and that the Contractor regards the order as a change order.
- c. Except as herein provided, no order, statement, or conduct of the Contracting Officer shall be treated as a change order under this clause or entitle the Contractor to an equitable adjustment hereunder.
- d. If any change under this clause causes an increase or decrease in the Contractor's cost of, or the time required for the performance of any part of the work under this contract, whether or not changed by any order, an equitable adjustment shall be made and the contract modified in writing accordingly, provided, however, that except for claims based on defective specifications no claim for any change under (b) above shall be allowed for any costs incurred more than 20 calendar days before the Contractor gives written notice as therein required. And provided further, that in the case of defective specifications for which the Owner is responsible, the equitable adjustment shall include any increased cost reasonably incurred by the Contractor in attempting to comply with such defective specifications.
- e. If the Contractor intends to assert a claim for an equitable adjustment under this clause, he must, within 30 calendar days after receipt of a written change order under (a) above or the furnishing of a written notice under (b) above, submit to the Contracting Officer a written statement setting forth the general nature and monetary extent of such claim, unless this period is extended by the Owner. The statement of claim hereunder may be included in the notice under (b) above.
- f. No claim by the Contractor for an equitable adjustment hereunder shall be allowed if asserted after final payment under this contract.

4. Specifications and Drawings

- a. The Contractor shall keep on the work site a copy of the drawings and specifications including all authorized change orders, and shall at all times give the Owner, Contracting Officer and their representatives access thereto.
- b. All drawings and specifications and copies thereof furnished by the Contracting Officer are his property and shall not be used on other projects without his consent. Upon completion of this project all copies of the drawings and specifications except the signed contract sets are to be returned to the Contracting Officer upon his request.

5. Special Requirements

Where special requirements, provisions or specifications or detailed specifications are attached hereto or are included in the proposal they shall be considered a part of these general conditions or specifications or detailed specifications as fully as if contained herein. Should any special provisions be in conflict with these general conditions or specifications or detailed specifications, said special requirements, provisions or detailed specifications shall govern.

6. Explanation to Bidders

No oral explanation in regard to the meaning of the drawings and specifications will be made and no verbal instructions will be given before the award of the contract. Discrepancies, omissions, or doubts as to the meaning of bid submittal documents, contract provisions, drawings and technical specifications should be communicated in writing to the Contracting Officer for interpretation. Bidders should act promptly and allow sufficient time for a reply to reach them. Every interpretation made to a bidder will be in the form of an addendum to the Invitation for Bids documents which, if issued, will be sent as promptly as practicable to all persons to whom the bid documents have been issued. All such addenda shall become part of the contract documents.

III. BIDS, BIDDER RESPONSIBILITIES

1. Conditions at Site or Building

- a. Bidders should visit the site and shall be responsible for having ascertained pertinent conditions such as location, accessibility, and general character of the site or building, the character and extent of existing work within or adjacent to the site, and any other work being performed thereon at the time of the submission of their bids. No extra compensation will be made by reason of any misunderstanding or error as regards to the site, the conditions thereof, accessibility or the amount of kind of work to be performed.
- b. If, in the performance of the contract, subsurface or latent conditions at the site are found to be materially different from those indicated by the drawings and specifications, or unknown conditions of an unusual nature are disclosed differing materially from the conditions usually inherent in work of the character shown and specified, the attention of the Contracting Officer shall be called immediately to such conditions before they are disturbed. Upon such notice, or upon his own observation of such conditions, the Contracting Officer shall promptly make such changes in the drawings and specifications as he finds necessary to conform to the different conditions, and any increase or decrease in the cost of the work resulting from such changes shall be adjusted as provided under Changes in Work.

2. Submission of Bids

- a. The bidder is required to bid on all items called for in the Bid Form.
- b. Bids shall be submitted on the forms furnished or copies thereof, and shall be signed in ink. Erasures or other changes in a bid must be explained or noted over the signature of the bidder. Bids containing any conditions, omissions, unexplained erasures or alterations or items not called for in the proposal or irregularities of any kind may be rejected by the Owner as being incomplete.
- c. Each bid must give the full business address of the bidder and be signed by him with his usual signature. Bids by partnerships must furnish the full names of all partners and must be signed in the name of the partnership by one of the members of the partnership or by an authorized representative followed by the

signature and designation of the person signing. Bids by corporations must be signed with the legal name of the corporation, followed by the name of the State of incorporation and by the signature and designation of the president, secretary, or other person authorized to bind it in the matter. The name of each person signing shall also be typed or printed below the signature. A bid by a person who affixes to his signature the word "president", (agent or other designation, without disclosing his principal), may be held to the bid of the individual signing. When requested by the Owner, satisfactory evidence of the authority of the officer signing in behalf of the corporation shall be furnished.

3. Bid Guarantee

Bids shall be accompanied by a bid guarantee of not less than fifteen percent (15%) of the total bid amount for which an award can be made. Bid guarantee may be bid bond (form enclosed), certified check or cashier's check. Bid bond shall be signed by the bidder, two major officers of the Surety and Resident General Agent, if the Surety is a foreign or alien surety and shall be accompanied with copies of current Certificate of Authority to do business on Guam issued by the Department of Revenue and Taxation, Power of Attorney issued by the Surety to the Resident General Agent and Power of Attorney issued by two major officers of the Surety to whoever is signing on their behalf. Certified check or cashier's check must be issued by a banking institution licensed to do business on Guam and shall be made payable to the Port Authority of Guam. Such bid bond or check shall be submitted with the understanding that it shall guarantee that the bidder will not withdraw his bid for a period of sixty (60) calendar days after the scheduled closing time for the receipt of bids; that if his bid is accepted, he will enter into a formal contract with the Owner in accordance with the form of agreement included as a part of the contract documents, and that the required performance and payment bond will be given; and that in the event of the withdrawal of said bid within said period, or the failure to enter into said contract and give said bond within ten (10) working days after he has received notice of the acceptance of his bid, the bidder shall be liable to the Owner for the full amount of the bid guarantee as representing the damage to the Owner on account of the default of the bidder in any particular hereof. The bid guarantee shall be returned to all except the three lowest bidders within three days after the formal opening of bids. The bid guarantee of the second and/or third low bidder shall be returned thirty (30) calendar days after the bid opening date upon request, provided that he has not been notified by the Owner of the acceptance of his bid prior to the date of such request. The bid guarantee of the lowest qualified bidder shall be returned within forty-eight (48) hours after the Owner and the qualified bidder have executed the contract.

4. Withdrawal of Bids

Bids may be withdrawn on written or telegraphic request received from bidders prior to the time fixed for opening. Negligence on the part of the bidder in preparing the bid confers no right to the withdrawal of the bid after it has been opened.

5. Publicity of Bids

At the time fixed for the opening of bids, the contents of the bids will be made public for the information of bidders and others properly interested who may be present either in person or by representation.

6. Receipt and Opening of Bids

- a. Bids will be opened publicly at the time and place stated in the invitation for bids. The officer whose duty it is to open them will decide when the specified time has arrived and bids received thereafter will not be considered. No responsibility will be attached to any officer for the premature opening of a bid not properly addressed and identified.
- b. Telegraphic bids will not be considered, but modifications by telegraph of bids already submitted will be considered if received prior to time set for opening.

7. Rejection of Bids

The Owner reserves the right to reject any and all bids in whole or in part when such rejection is in the interest of the Owner and to reject the bid of a bidder who is not in a position to perform the contract.

8. Award of Contract

- a. The contract will be awarded as soon as possible to the lowest responsive and responsible bidder, provided it is in the interest of the Owner to accept his bid.

- b. The Owner reserves the right to waive any informality in bids received when such waiver is in the interest of the Owner. The Owner also reserves the right to accept any item in the bid and to reject any item in the bid unless otherwise specified by the Owner.
- c. Multiple, Alternate, or Late Bids. Multiple or Alternate Proposals will not be accepted, and any multiple or alternate Proposals submitted will be rejected. Late Proposals will not be accepted, and any late Proposals will be rejected.
- d. All or None Bids. Bids MAY NOT limit acceptance to the entire bid or Proposal offering. Proposals that violate this provision shall be deemed to be nonresponsive.

9. Performance and Payment Bond

The successful bidder must deliver to the Owner an executed performance and payment bond (forms enclosed) in an amount at least equal to one hundred percent (100%) of the accepted bid as security for the faithful performance of the contract and security for the payment of all persons performing labor and furnishing materials in connection with this contract. The sureties of all bonds shall be such surety company or companies as are approved by the Owner and as are authorized to transact business in Guam. The bonds must be approved by the Owner prior to execution of the formal contract.

10. Cancellation of Award

The Owner reserves the right to cancel the solicitation cancellation award of any contract at any time before the execution of same.

11. Terms for Multi-Term Contracts

Any contract awarded under this IFB is subject to the availability of certified funds. The Procurement Officer will notify the Contractor on a timely basis whether the funds are, or are not, available for the continuation of the contract for each succeeding fiscal period. In the event that funds are not available for any succeeding fiscal period, the contract shall be cancelled; however, this does not affect either Party's right to terminate under the termination clauses of the contract. If the contract is cancelled for insufficient funds, the awarded Contractor shall be reimbursed its unamortized, reasonably incurred, non-recurring costs.

IV. DUTIES OF CONTRACTING OFFICER AND CONTRACTOR SAFETY MEASURES

1. AUTHORITY OF CONTRACTING OFFICER

The Contracting Officer shall give all orders and directions contemplated under this contract and specifications relative to the execution of the work. The Contracting Officer shall determine the amount, quality, acceptability, and fitness of the several kinds of work and materials which are to be paid or under this contract and shall decide all questions which may arise in relation to paid work and the construction thereof. The Contracting Officer's estimates and decisions shall be final and conclusive, except as herein otherwise expressly provided. In case any question shall arise between the parties hereto relative to said contract or specifications, the determination or decision of the Contracting Officer shall be a condition precedent to the right of the Contractor to receive any money or payment for work under this contract affected in any manner or to any extent by such question.

The Contracting Officer shall decide the meaning and intent of any portion of the specifications and of any plans or drawings where the same may be found obscure or be in dispute.

Any difference or conflicts in regard to their work which may arise between the Contractor under this contract and other Contractors performing work for the Owner shall be adjusted and determined by the Contracting Officer.

2. CONTRACTOR'S OBLIGATIONS

The Contractor shall, in good workmanlike manner, do and perform all work and furnish all supplies and materials, machinery, equipment, facilities and means, except as herein otherwise expressly specified, necessary or proper to perform and complete all the work required by this contract within the time herein specified in accordance with the plans and drawings of the work covered by this contract and any and all supplemental plans and drawings, and in accordance with the directions of the Contracting Officer as given from time to time during the progress of the work. He alone shall be responsible for the safety, efficiency and adequacy of his plant, appliances and methods,

and for any damage which may result from their failure or their improper construction, maintenance or operations. The Contractor shall observe, comply with and be subject to all terms, conditions, requirements, and limitations of the contract and specifications and shall do carry on and complete the entire work to the satisfaction of the Contracting Officer and the Owner.

3. SUPERINTENDENCE BY CONTRACTOR

The Contractor shall give his personal superintendence to the work or have a competent foreman or superintendent, satisfactory to the Contracting Officer, on the work at all times during progress with authority to act for him.

4. SUBCONTRACTS

- a. Nothing contained in the specifications or drawings shall be construed as creating any contractual relationship between any subcontractor and the Owner. The diffusion or sections of the specifications are not intended to control the Contractor in dividing the work among subcontractors or to limit the work performed by any trade.
- b. The Contractor shall be as fully responsible to the Owner for the acts and omissions of subcontractors and of persons employed by them, as he is for the acts and omissions of persons directly employed by him.
- c. The Contractor shall be responsible for the coordination of the trades, subcontractors, and material-men engaged in his work.
- d. The Contractor shall, without additional expense to the Owner, utilize the services of specialty subcontractors on those parts of the work which are specified to be performed by specialty subcontractors.
- e. The Owner will not undertake to settle any differences between the Contractor and his subcontractors or between subcontractors.
- f. The Contractor shall cause appropriate provisions to be inserted in all subcontracts relative to the work including waiver of mechanic's liens to bind subcontractors by the terms of the General Conditions and other contract documents insofar as applicable to the work of subcontractors and to give the Owner any exercise over the Contractor under any provisions of the contract documents.

5. SUBLETTING

Subletting part of the work is permitted. However, bidder must note that subletting in excess of the following is not allowed:

- a. Where the subletting is for both labor and material, total cost of sublet work shall not exceed 50% of the contract amount.
- b. Where subletting is for labor only, sublet work cost shall not exceed 30% of the total labor contract amount. Information concerning subcontracts must form a part of the bid documents and shall be submitted on standard "Subcontract" information form.

6. ASSIGNMENTS

The Contractor shall not assign the whole or any part of this contract or any monies due or to become due hereunder without the written consent of the Owner and of all the sureties executing any bonds on behalf of the Contractor in connection with said contract. In case the Contractor assigns the whole or any part of said contract or assigns all or any part of any monies due or to become due under said contract, the instrument of assignment shall contain a clause substantially to the effect that it is agreed that the right of the assignee in and to any monies due or to become due the Contractor or otherwise shall be subject to all of the terms and conditions of said contract or supplemental thereto, the rights and remedies of the Owner thereunder or arising by operation of the law and to the liens of all persons, firms, and corporations for services rendered or materials supplied in connection with the performance of said contract.

7. EQUAL EMPLOYMENT OPPORTUNITY

In accordance with Governor of Guam's Executive Order 2006-16 and in compliance with the 14th Amendment to the Constitution, Section 5 (Bill of Rights) and 9(a) (Merit System), and federal laws; Title VI and VII of the Civil Rights Act.; the Civil Rights Act of 1991; Title I of the American Disabilities Act; the Equal Pay Act; the Age Discrimination in Employment Act; Section 504 of the Vocational Rehabilitation Act; Title IX of the Education Amendments of 1972; other pertinent federal laws and Guam laws; Title 4 of the Guam Code Annotated; Title 17, Chapter 2 of the Guam Code Annotated; Public law 14-28, Section 5; Public Law 15-17; Public Law 28-68; Public law 28-112 and other pertinent laws, it is the intent of the Government of Guam, hereinafter the Government:

- a. To provide equal employment opportunity for all applicants and employees to compete and be considered for jobs on the basis of merit and ability to perform, and to prohibit discrimination in any aspect, term, condition or privilege of employment on the basis of race, religion, color, sex, including sexual harassment and orientation, national origin, age, physical or mental disability, marital status, or political affiliation and retaliation. *Such discrimination against any person in recruitment, examination, appointment, training, promotion, retention, discipline, or any other aspect of personnel administration is prohibited.
 - *Except where specific factors legally constitute a bona fide occupational qualification or in the case of specifically funded programs to facilitate the employment of disadvantaged persons, but only with the prior approval of the Equal Opportunity Administrator.*
- b. To carry out all government programs and activities in compliance with applicable Federal and Territorial laws and in such a manner that no person shall, on a basis of race, religion, color, sex, including sexual harassment and orientation, national origin, age, physical or mental disability, marital status, or political affiliation and retaliation be excluded from participation in, be denied the benefits of, or be subjected to discrimination with respect to any program or activities.

8. HIRING OF APPRENTICES

The Contractor shall, except of good cause shown, hire for performance of work under this contract, to the extent possible, apprentices in each occupation to be employed in the performance of work under this contract in accordance with Executive Order No. 2000-10 dated April 11, 2000.

9. MINIMUM WAGE RATE

All persons employed on this project shall be paid not less than minimum wage applicable to the corresponding skill or craft as determined by the Department of Labor, Government of Guam. Prevailing wage rates of Department of Labor, Government of Guam are attached herewith and shall be deemed a part of the contract documents. Additional requirements may be found in the scope of work.

10. LAWS, PERMITS AND REGULATIONS

- a. The DPW building, and federal permit that is required for the project shall be secured and paid for by the Contractor.
- b. The Contractor shall pay all fees and charges for connection to outside service and use of property other than the site of the work for storage of materials or other purposes.
- c. The Contractor shall comply with all laws, ordinances, regulations and building code requirements applicable to work hereunder unless in conflict with contract requirements. If the Contractor ascertains at any time that any requirement of this contract is a variance with applicable laws, ordinances, regulations, or building code requirements, he shall promptly notify the Contracting Officer and any necessary adjustment of the contract shall be made as specified under Changes in Work.

11. CONTRACTOR'S AND SUBCONTRACTOR'S INSURANCE

- a. Prior to commencing the work, Contractor shall obtain and thereafter maintain during the course of the work Insurance with companies acceptable to Owner. The Contractor shall not allow any subcontractor to commence work on his subcontract until all similar insurance required of the subcontractor has been so obtained and approved. The limits of insurance shall be as follows unless a higher limit is required by statute:

- i. Comprehensive General Liability including products, completed operations and contractual coverage for this Agreement in the amount of \$1,000,000 combined single limit. Owner shall be an additional insured.
 - ii. Auto Liability Insurance covering bodily injury and property damage in the amount of \$1,000,000 combined single limit. Owner shall be an additional insured.
 - iii. Excess Liability Policy with limits of \$1,000,000 or higher.
 - iv. Owner shall be an additional insured.
 - v. Worker's Compensation and Employer's Liability- Statutory limits. Add Waiver of Subrogation endorsement in favor of Owner.
 - vi. Builder's Risk or Installation Floater, when applicable, is to be furnished by Contractor, which shall include Owner as named insured.
- b. Contractor shall furnish certificates of insurance and waiver of subrogation endorsement to Owner prior to commencement of work showing evidence of such coverage, including the statement to the effect that cancellation or termination of the insurance shall not be effective until at least ten (10) days after receipt of written notice to Owner. At all times Contractor's insurance shall be primary to any other insurance that may be carried by Owner. The statement of limits of insurance coverage shall not be construed as in any way limiting the Contractor's liability under this agreement. Owner shall be an additional insured on all liability coverage and certificates of insurance shall clearly indicate as such.

12. INDEMNITY

- a. Indemnity: The Contractor shall indemnify, defend and hold harmless Owner against all loss, damage, or expense (including reasonable attorney's fees incurred by Owner) arising out of the performance of the work, including injury or death to any person or persons resulting from the acts of omission of the Contractor or the Contractor's employees, servants, agents or subcontractors and from mechanics and material man's liens.

13. ACCIDENT PREVENTION

- a. Precaution shall be exercised at all times for the protection of persons (including employees) and property. The safety provisions of applicable laws, building and construction codes shall be observed. Machinery equipment and all hazards shall be guarded or eliminated in accordance with the safety provisions of the latest edition of the Manual of Accident Prevention in Construction published by the Associated General Contractors of America to the extent that such provisions are not in contravention of applicable laws.
- b. Should typhoon warnings be issued, the Contractor shall take every practicable precaution to minimize damage and/or danger to persons, to the work, and to the adjacent property. These precautions shall include closing all openings, removing all loose materials, tools and/or equipment from exposed locations, and removing or securing scaffolding and all other temporary work.

14. PROTECTION OF WORK AND PROPERTY

The Contractor shall at all times safely guard the Owner's property from injury or loss in connection with this contract. He shall at all times safely guard and protect his own work and that of adjacent property (as provided by law and the contract documents) from damage. All passageways, guard fences, lights and other facilities required for protection by laws and regulations and local conditions must be provided and maintained.

15. RESPONSIBILITY OF CONTRACTOR TO ACT IN EMERGENCY

In case of an emergency which threatens loss or injury of property and/or safety or life, the Contractor shall act, without previous instructions from the Owner or Contracting Officer, as the situation may warrant. He shall notify the Contracting Officer thereof immediately thereafter of any compensation claimed by the Contractor. Substantiating documents regarding expenses shall be submitted to the Owner through the Contracting Officer and the amount of compensation shall be determined by agreement or by the Contracting Officer subject to review procedures provided under Guam's Procurement Law and Claims Act.

16. MUTUAL RESPONSIBILITY OF CONTRACTORS

If the Contractor or any of his subcontractors or employees causes loss or damage to any separate contractor on the work, the Contractor agrees to settle with such separate contractor by agreement, if he will so settle. If such separate contractor sues the Owner on account of any loss so sustained, the Owner shall notify the Contractor who shall indemnify and save harmless the Owner against any expenses or judgments arising therefrom.

17. USE OF PREMISES AND REMOVAL OF DEBRIS:

The Contractor expressly agrees to undertake at his own expense

- a. to take every precaution against injuries to persons or damages to property;
- b. to comply with the regulations governing the operation of premises which are occupied and to perform his contract in such a manner as not to interrupt or interfere with the operation of other facilities;
- c. to perform any work necessary to be performed after regular working hours or on Sundays or legal holidays without additional expense to the Owner;
- d. to store his apparatus, materials, supplies, and equipment in such orderly fashion at the site of the work as will not unduly interfere with the progress of his work or the work of any other contractors;
- e. to place upon the work or any part thereof only such loads as are consistent with the safety of that portion of the work;
- f. to frequently clean up all refuse, rubbish, scrap materials and debris caused by his operation so that at all times the site of the work shall present a neat, orderly and workmanlike appearance;
- g. to effect all cutting, fitting, or patching of his work required to make the same conform to the plans and specifications, and except with the consent of the Contracting Officer, not to cut or otherwise alter the work of any contractor;
- h. before final payment to remove all surplus materials, false work, temporary structures, including foundations thereof, plant of any description and debris of every nature resulting from his operations, to put the site in a neat, orderly condition and to thoroughly clean and leave reasonably dust free all furnished surfaces.

18. OBSTRUCTIONS

The Contractor shall at his own expense remove all obstructions, the removal of which shall be necessary for the proper reception, performance, construction, installation and completion of all work under this contract.

19. SITE OF CONTRACTOR'S OPERATIONS

The Contractor shall confine all construction operations within the vicinity of the site and shall arrange his work so that all construction materials and equipment are placed in such manner and location that there may be a minimum of interference or inconvenience inflicted upon the public and employees of the Government.

20. BARRICADES

The Contractor shall erect, install and maintain all temporary public walks, warning signs, barricades or other protective means in and around the site as deemed necessary or as may be ordered by the Contracting Officer for the effective protection of the public from injury and shall be held strictly liable for their safety.

21. ELECTRICAL ENERGY

The Contractor shall make all necessary applications, pay all fees and charges, obtain necessary permits and provide and maintain his own electrical power and light as required and necessary in the progress of any branch of the work. He shall provide all temporary wiring necessary.

22. WATER

The Contractor shall make all necessary applications, pay all fees and charges, and obtain necessary permits for construction of temporary water required for use on this project. The nearest available source of water tap shall be verified by the Contractor. The Contractor shall be responsible for all expenses required for conveying water to the site from the available nearest source.

23. SIGNS

The Contractor shall erect a sign at the project site at his own expense. The location of the sign shall be as directed by the Contracting Officer. Size of signs, lettering, and other pertinent data that should appear on the sign will be furnished by the Contracting Officer to the Contractor.

V. QUALITY OF WORK

1. Engineering and Layout

- a. The Contractor shall provide competent engineering services to execute the work in accordance with the contract requirements. He shall verify the figures shown on the survey and approach drawings before undertaking any construction work and shall be responsible for the accuracy of the finished work.
- b. The Owner has established or will establish such general reference points as will, in his judgment, enable the Contractor to proceed with the work. If the Contractor finds that any previously established reference points have been destroyed or displaced, he shall promptly notify the Owner.
- c. The Contractor shall protect and preserve the established bench marks and monuments and shall make no changes in location without the written approval of the Owner. Any of them which may be lost or destroyed or which require shifting because of necessary changes in grades or locations shall be subject to prior approval by the Owner, be replaced and accurately located by the Contractor.

2. SHOP DRAWINGS, MATERIALS AND WORKMANSHIP

Unless otherwise specified, all materials and equipment incorporated in the work under the contract shall be new. All workmanship shall be first class and by persons qualified in the respective trades.

Shop Drawings

- a. The Contractor shall submit, for the approval of the Contracting Officer, shop and setting drawings and schedules required by the specifications or that may be requested by the Contracting Officer and no work shall be fabricated by the Contractor, save at his own risk, until such approval has been given.
- b. Drawings and schedules shall be submitted in quadruplicate (unless otherwise specified) accompanied by letter of transmittal which shall give a list of the numbers and dates of the drawings submitted. Drawings shall be complete in every respect and bound in sets.
- c. The Contractor shall submit all drawings and schedules sufficiently in advance of construction requirements to allow ample time for checking, correcting, resubmitting and rechecking.
- d. The drawings submitted shall be marked with the name of the project, numbered consecutively and bear the stamp of approval of the Contractor as evidence that the drawings have been checked by the Contractor. Any drawings submitted without this stamp of approval will not be considered and will be returned to the Contractor for resubmission. If the shop drawings show variations from the requirements of the contract because of standard shop practice or other reasons, the Contractor shall make specific mention of such variation in his letter of transmittal in order that if applicable, suitable action may be taken for proper adjustment. Otherwise, the Contractor will not be relieved of the responsibility for executing the work in accordance with the contract even though such shop drawings have been approved.
- e. If a drawing as submitted indicates a departure from the contract requirements which the Contracting Officer finds to be in the interest of the Owner and to be so minor as not to involve a change in the contract price or time for performance, he may approve the drawings.
- f. The approval of shop and setting drawings will be general and, except as otherwise provided in paragraph 2 (e), shall not be construed (1) as permitting any departure from the contract requirements;

(2) as relieving the Contractor of the responsibility for any error in details, dimensions or otherwise that may exist; (3) as approving departures from additional details or instructions previously furnished by the Contracting Officer.

3. STANDARDS

- a. Any material specified by reference to the number, symbol or title of a specific standard, such as a commercial standard, a Federal specification, a trade association standard or other similar standard, shall comply with the requirements in the latest revision thereto in effect on the date of Invitation for Bids, except as limited to type, class or grade or modified in such reference.
- b. The standard referred to, except as modified in the specifications, shall have full force and effect as though printed in the specifications. These standards are not furnished to bidders for the reason that the manufacturers and trades involved are assumed to be familiar with their requirements. The Contracting Officer will furnish, upon request, information as to how copies of such standards may be obtained.
- c. Reference in the specifications to any article, device, product, material, fixture, form, or type of construction by name, make or catalog number shall be interpreted as establishing a standard of quality and shall not be construed as limiting competition; and the Contractor, in such cases, may at his option use any article, device, product, material, fixture, form of type of construction which in the judgment of the Contracting Officer expressed in writing is equal to that specified.

4. SAMPLES

- a. The Contractor shall furnish for the approval of the Contracting Officer any samples required by the specifications or that may be required by the Contracting Officer of any and all materials or equipment he proposes to use and shall prepay all shipping charges on the samples.
- b. No samples are to be submitted with bids.
- c. No materials or equipment of which samples are required to be submitted for approval shall be used on the work until such approval has been given by the Contracting Officer, save only at the Contractor's risk and expense.
- d. Each sample shall have a label indicating the material represented, its place of origin and the names of the producer, the Contractor and the building or work for which the material is intended. Samples of finished materials shall be so marked as to indicate where the materials represented are required by the drawings or specifications.
- e. A letter in duplicate submitting each shipment of samples shall be mailed under separate cover by the Contractor and contain a list of the samples, the name of the building or work for which the materials are intended, and the brands of the materials and names of the manufacturers.
- f. The approval of any sample shall be only for characteristics or for the named in such approval and no other. No approval of a sample shall be taken in itself to change or modify any contract requirement. When a material has been approved, no additional sample of that material will be considered and no change in brand or make will be permitted. Approval of samples of hardware in good condition may be suitably marked for identification and used in the work.
- g. Failure of any material to pass the specified tests will be sufficient cause for refusal to consider under this contract any further samples of the same brand or make of that material.
- h. Test samples as the Contracting Officer may deem necessary will be procured from the various materials or equipment delivered by the Contractor for use in the work. If any of these test samples fail to meet the specifications requirement, any previous approvals will be withdrawn and such materials or equipment shall be subject to removal and replacement by the Contractor with materials or equipment meeting the specification requirements, or at the discretion of the Owner, the defective materials and equipment may be permitted to remain in place subject to a proper adjustment of the contract price. The cost of the tests will be borne by the Owner except where laboratory tests as hereinafter specified are required by the specifications.

5. LABORATORY TESTS

- a. Any specified laboratory tests of materials and finished articles to be incorporated in the work shall be made by bureaus, laboratories or agencies approved by the Contracting Officer, and the reports of such tests shall be submitted to the Contracting Officer. The cost of the testing shall be paid for by the Contractor.

6. METHODS

The Contractor shall use proper and efficient methods and appliances for the performance of all the operations connected with work embraced under these specifications, drawings and contract to secure a rate of progress which will secure completion of the work within the time specified. If, at any time before commencement of work, or during the progress thereof, such methods, equipment or appliances are inefficient or inappropriate for securing said quality of work or said rate of progress, the Contracting Officer may order the Contractor to increase their efficiency or to improve their character, and the Contractor must conform to such order. The failure of the Contracting Officer to demand such increases of efficiency or improvement shall not relieve the Contractor or his sureties from the obligations to secure such quality of work and said rate of progress and the completion of the work as required herein.

7. LABOR AND MATERIALS

The Contractor shall furnish all labor, materials and equipment for the execution of the work according to the drawings, specifications and contract, and where no specifications are contained therein for whatever may be necessary, shall do all that may be termed ordinary, customary or essential to a job to be well and reliably completed. This includes concealment of all pipes and other rough items of installation if not clearly so shown on the drawings in a manner acceptable to the Contracting Officer. Structural safety shall not be impaired by such concealment. Work not particularly detailed, marked or specified shall be of equal quality as similar parts that are detailed, marked or specified. All material finished for and used in the job shall be of kind and grade specified and where not specifically called for at least of customary standard grade. All work shall be executed in accordance with their trades. Full structural safety is essential and the Contractor guarantees to accomplish same for the entire work.

8. GUARANTEE OF WORK

- a. Except as otherwise specified all work shall be guaranteed by the Contractor against defects resulting from the use of inferior materials, equipment, or workmanship for one year from the date of final completion of the contract or from full occupancy of the building by the Owner, whichever is earlier.
- b. If within any guarantee period, repairs or changes are required in connection with guaranteed work which, in the opinion of the Contracting Officer, is rendered necessary as the result of the use of materials, equipment or workmanship which are inferior, defective or not in accordance with the terms of the contract, the Contractor shall promptly upon receipt of notice from the Owner and without expense to the Owner:
 - i. Place in satisfactory condition in every particular all of such guaranteed work and correct all defects therein; and
 - ii. Make good all damages to the building or site or equipment or contents thereof which, in the opinion of the Contracting Officer, are the result of the use of materials, equipment or workmanship which are inferior, defective or not in accordance with the terms of the contract.
- c. In any case wherein fulfilling the requirements of the contract or of any guarantee embraced in or required thereby the Contractor disturbs any work guaranteed under another contract, he shall restore such disturbed work to a condition satisfactory to the Contracting Officer and guarantee such restored work to the same extent as it was guaranteed under such other contract.
- d. If the Contractor, after notice, fails to proceed promptly to comply with the terms of the guarantee, the Owner may have the defects corrected and the Contractor and his surety shall be liable for all expense incurred.

- e. All special guarantees applicable to definite parts of the work shall be stipulated in the specifications or other papers forming a part of the contract and shall be subject to the terms of this paragraph during the life of such special guarantee.

9. DEFECTIVE WORK

No work or material which may be defective in construction or quality or deficient in any of the requirements of the drawings and specifications will be considered accepted as a consequence of the failure of the Contracting Officer or the inspectors to discover or to point out said defects or deficiencies during the construction; nor will the presence of inspectors on the work relieve the Contractor from the responsibility of securing the quality and progress of work as required by these specifications.

Any defective work that may be discovered before the completion of the work or within such time as required by the bond shall be replaced by work and materials that shall conform to the spirit and intent of the drawings, specifications and contract.

The fact that the Contracting Officer or his representatives may have overlooked defective work shall not constitute the acceptance of work.

NO PAYMENT WHETHER PARTIAL OR FINAL SHALL BE CONSTRUED TO BE AN ACCEPTANCE OF DEFECTIVE WORK OR IMPROPER MATERIALS.

The Contracting Officer may at any time by order given in writing stop any work not being done according to drawings and specifications and any order so given shall not in any way relieve the Contractor from completing his contract and shall not in any way terminate, cancel or abrogate the contract or any part thereof, and the Port Authority of Guam shall not in any way be responsible for the delay due to stopping the work as aforesaid.

VI. INSPECTION OF WORK

1. Access to the Work

The Contracting Officer and his representatives shall have access at all times to the work for inspection whatever it is in preparation or progress and the Contractor shall provide proper facilities for such access and inspection.

2. Inspectors

Inspectors may be placed by the Contracting Officer to supervise each and every subdivision of the work or any parts or process thereof. The Contracting Officer and the inspectors shall have free access to all parts of the work at all times and shall be given every facility, information and means of thoroughly inspecting the work done and the materials used or to be used.

The inspectors shall at all times be free to perform their duties and any intimidation of any inspector by the Contractor or the employees thereof shall be sufficient reason, if the Owner shall so decide, to annul the contract.

3. As-Built Drawings

A contract set of drawings shall be maintained at the site with all changes or deviations from the original drawings neatly marked thereon in brightly contrasting color. This shall be a separate set of drawings not used for construction purposes which shall be kept up to date as the job progresses and shall be made available for inspection by the Contracting Officer at all times. The Contractor shall submit a record copy of as-built drawings and an electronic file of as-built drawings within thirty (30) days of the substantial completion and/or final acceptance of the project. As-built drawings shall be marked "As-Built Drawing" with Contractor's signature and date. The electronic file of as-built drawings shall be drawn in Auto Cad Release 14 or later version as required by the Contracting Officer.

4. As-Built Record of Materials:

Unless provided under the contract specifications, furnish within 10 calendar days of the beneficial occupancy date a record of materials used prior to completion of the contract. Submission of this data is a condition for final payment under the contract.

5. Inspection

- a. All materials and workmanship (if not otherwise designated by the specifications) shall be subject to inspection, examination and testing by the Contracting Officer at any and all times during manufacture and/or construction and at any and all places where such manufacture and/or construction are carried on. The Contracting Officer shall have the right to reject defective material and workmanship or require its correction. Rejected workmanship shall be satisfactorily corrected, and rejected materials shall be satisfactorily replaced with proper materials and the Contractor shall promptly segregate and remove the rejected materials from the premises. If the Contractor fails to proceed at once with the replacement of rejected materials and/or the correction of defective workmanship, the Owner may, by contract or otherwise, replace such materials and/or correct such workmanship and charge the cost to the Contractor, or may terminate the right of the Contractor to proceed as provided in paragraph 5 of Section VII, Time for Performance, the Contractor and surety being liable for any damage to the same extent as provided in said paragraph 16 for termination thereunder.
- b. The Contractor shall furnish promptly, without additional charge, all reasonable facilities, labor and materials necessary for the safe and convenient inspection and tests that may be required by the Contracting Officer. All inspections and tests shall be performed in such manner as not to unnecessarily delay the work. Special, full-size and performance tests shall be as described in the specifications. The Contractor shall be charged with any cost of inspection when material and workmanship are not ready at the time inspection is requested by the Contractor.
- c. Should it be considered necessary or advisable by the Contracting Officer at any time before final acceptance of the entire work to make an examination of work already completed by removing or tearing out same, the Contractor shall on request promptly furnish all necessary facilities, labor and materials. If such work is found to be defective in any material respect due to the fault of the Contractor or his subcontractors, he shall defray all the expenses of such examination and of satisfactory reconstruction.

If, however, such work is found to meet the requirements involved in the examination and replacement, the cost of conducting the test plus 15 percent shall be allowed the Contractor and he shall in addition, if completion of the work has been delayed thereby, be granted a suitable extension of time on account of the additional work involved.

6. Final Inspection

When the work is substantially completed the Contractor shall notify the Owner, in writing, that the work will be ready for final inspection and test on a definite date which shall be stated in such notice. The notice shall be given at least ten (10) calendar days in advance of said date and shall be forwarded through the Contracting Officer who will attach his endorsement as to whether or not he concurs in the Contractor's statement that the work will be ready for final inspection or tests on the date given but such endorsement shall not relieve the Contractor of this responsibility in the matter.

VII. TIME FOR PERFORMANCE

1. Prosecution of the Work

The Contractor agrees that said work shall be prosecuted regularly, diligently and without interruption at such rate of progress as will insure full completion thereof within the time specified. It is expressly understood and agreed by and between the Contractor and the Owner that the time for completion of the same takes into consideration the average climatic range and usual industrial conditions prevailing in the locality.

2. Injunction

The Owner will furnish all land and rights-of-way necessary for the carrying out of this contract and the completion of the work herein contemplated. Should the Owner be prevented or enjoined from proceeding with the work or from authorizing its prosecution, either before or after the commencement by reason of any litigation, the Contractor shall not be entitled to make or assert any claim for damage by reason of said delay, or to withdraw from the contract except by consent of the Owner, but time for completion of the work will be extended to such time as the Contracting Officer determines will compensate for the time lost by such delay determination to be set forth in writing.

3. Climatic Conditions

- a. When so ordered by the Contracting Officer, the Contractor shall suspend any work that may be subject to damage by climatic conditions.
- b. Contract Completion Time. The allowable work days for this contract were calculated after allowing for the following number of lost days in each month.

Time extension on account of inclement weather will be allowed only if the daily report of the Contracting Officer's inspector indicates lost days beyond the limits shown below. Time extension on account of inclement weather on Saturday and Sunday shall be granted only if the Contractor confirms in writing at least seven (7) days in advance his intention to work on weekends.

4. Progress Report

The Contractor shall submit monthly progress report in triplicate to the Contracting Officer briefly setting forth work accomplished.

5. Owner's Right to Stop Work or Terminate Contract, Delays, Damages

- a. The Owner's shall have the Right to Stop Work or Terminate the Contract for delays if:
 - i. The Contractor shall be adjudged bankrupt or make an assignment for the benefit of creditors;
 - ii. A receiver or liquidator shall be appointed for the Contractor or for any of his property and shall not be dismissed within 20 calendar days after such appointment, or the proceedings in connection therewith shall not be stayed on appeal within the said 20 calendar days;
 - iii. The Contractor shall refuse or fail, after Notice of Warning from the Contracting Officer, to supply enough properly skilled workmen or proper materials; or
 - iv. The Contractor shall refuse to prosecute the work or any part thereof with such diligence as will insure its completion within the period herein specified (or any duly authorized extension thereof) or shall fail to complete the work within said period, or;
 - v. The Contractor shall fail to make payments as specified to persons supplying labor or materials for the work, or;
 - vi. The Contractor shall fail or refuse to regard laws, ordinances or the instructions of the Contracting Officer or otherwise be guilty of a substantial violation of any provision(s) of this contract, then, and in any such event, the Owner, upon the certificate of the Contracting Officer that sufficient cause exists to justify such action, and without prejudice to any other rights or remedy he may have may, with 10 calendar days' notice to the Contractor, terminate the employment of the Contractor and his right to proceed, either as to the entire work or (at the option of the Owner) as to any portion thereof as to which delay shall have occurred, and may take possession of the work and complete the work by contract or otherwise as the Owner may deem expedient. In such case the Contractor shall not be entitled to receive any further payment on that work until the work is finished. If the unpaid balance of the compensation to be paid the Contractor hereunder shall exceed the expense of so completing the work (including compensation for additional managerial, administrative, and inspection services and any liquidated damages for delay), such excess shall be paid to the Contractor. If such expense shall exceed such unpaid balance, the Contractor and his sureties shall be liable to the Owner for such excess. If the right of the Contractor to proceed with the work is so terminated, the Owner may take possession of and utilize in completing the work such materials, supplies, plant, and equipment as may be on the site of the work and necessary therefore. The expenses incurred through the Contractor's default shall be certified by the Contracting Officer.
- b. If the Owner does not terminate the right of the Contractor to proceed, the Contractor shall continue the work, in which event the Contractor shall pay to the Owner as fixed, agreed, and liquidated damages for each calendar day of the delay until work is completed or accepted the amount as set forth in the section of the specifications and the Contractor and his sureties shall be liable for the amount thereof.

- c. Provided that the right of the Contractor to proceed shall not be terminated, or the Contractor charged with liquidated damages because of any delays in the completion of the work due to unforeseeable cause beyond the control and without the fault or negligence of the Contractor including, but not restricted to, acts of God or of the public enemy, acts of the Owner, acts of another Contractor in the performance of a contract with the Owner, fires, floods, epidemics, quarantine restrictions, strikes, freight embargoes, and unusually severe weather, or delays of subcontractors due to such cases, if the Contractor shall, within ten days from the beginning of any such delay (unless the Owner shall grant a further period of time prior to the date of final settlement of the contract) notify the Owner in writing of the causes of delay through the Contracting Officer, who shall ascertain the facts and the extent of the delay and extend the time for completing the work when in his judgment the findings of facts justify such an extension, and his findings of fact thereon shall be final and conclusive on the parties hereto subject only to review procedures provided under Guam's Procurement Law and Claims Act.

VIII. CLAIMS, PAYMENTS

1. Contractor's Title to Materials

No materials or supplies for the work shall be purchased by the Contractor or by any subcontractor subject to any chattel mortgage or under a conditional sale or other agreement by which an interest is retained by the seller. The Contractor warrants that he has good title to all materials and supplies for which he accepts partial payments.

2. Claims

The Contractor agrees whenever required to do so by the Owner to furnish satisfactory evidence that all persons, firms or corporations who have done work or supplied materials under these specifications have been paid or have been duly notified of the completion of the work and have been secured to their satisfaction before the said Contractor shall be entitled to final payment.

In case such evidence is not furnished or in case any claim is filed with the Owner or any suit or action is instituted against the Owner as defendant or garnishee or against the Contractor in connection with the work performed or to be performed under the drawings, specifications or contract, the Owner may retain from the money due or to become due to the Contractor such sum or sums as in the judgment of the Contracting Officer will fully protect the Owner from loss, charge or expense by reason of such claim, suit or action. The Owner without prejudice to any other and further rights, may make any and all deductions for any loss, charge or expense sustained by it to which it would be entitled under the contract specifications or bond, or otherwise before paying over the balance of the sum or sums retained as aforesaid, if any, to the Contractor, his creditor, or any successful claimant against the Contractor.

No payment made or retained under this contract shall be held to relieve the Contractor and/or his sureties from his and/or their obligations under this bond to hold harmless and indemnify the Owner or its agents from any and all loss, charge or expense by reason of any unpaid claim whatsoever.

3. Waiver of Mechanics Liens

Contractor waives any right that he now has or in the future may have to claim a mechanic's lien against the real property or improvements thereon which are the subject of this contract, to secure payment for labor and materials furnished or to be furnished by him under this contract.

4. Schedule of Values

Within fourteen (14) days after receipt of notice to proceed, the Contractor shall submit for approval a schedule of the estimated values of the main branches of the work totaling the amount of the contract. The format to be used will be furnished by the Contracting Officer. These values will be used for determining partial payments and as a basis for changes in work as outlined in the General Conditions.

5. Taxes

The Contractor shall, without additional expense to the Owner, pay all applicable taxes. The successful bidder will be required to comply with the applicable sections of Titles 11 and 21 of the Guam Code Annotated, as

regards to licenses and taxes. In addition to the general contractor's liability, subcontractors are also subject to these provisions. Subcontractors are also required to possess Guam Service Licenses. The Contractor will be required to submit a list of his subcontractors and the monetary amount of each subcontract. All procurements of professional services are subject to a withholding assessment fee for non-resident persons or companies without a valid Guam Business License, which is equal to four percent (4%) of the total dollar value of any contract awarded for all government of Guam contracts for any professional services provided by a non-resident person or company residing outside of Guam, as a cost of doing business with the government of Guam, in accordance with 11 GCA § 71114 (P.L. 33-166).

6. Materials, Services and Facilities

It is understood that except as otherwise specifically stated in the contract documents, the Contractor shall provide and pay for all materials, labor, tools, equipment, water, light, power, transportation, superintendence, temporary construction of every nature whatsoever necessary to execute, complete and deliver the work within the specified time.

7. Patents

The Contractor shall hold and save the Owner and his officers, agents, servants, and employees harmless from liability of any nature or kind, including cost and expenses, for or on account of any patented or unpatented invention, process, article or appliance manufactured or used in the performance of the contract including its use by the Owner, unless otherwise specifically stipulated in the contract documents.

8. Payment by Contractor

The Contractor shall pay:

- a. for all transportation and utility services not later than the 20th day of the calendar month following that in which such services are rendered;
- b. for all materials, tools, and other expendable equipment to the extent of 90 percent of the cost thereof, not later than the 20th day of the calendar month following that in which such materials, tools and equipment are delivered at the site of the project, and the balance of the cost thereof not later than the 30th day following the completion of that part of the work in or on which such materials, tools and equipment are incorporated or used;
- c. to each of his subcontractors, not later than the 5th day following each payment to the Contractor, the respective amounts allowed the Contractor on account of the work performed by his subcontractors, to the extent of such subcontractor's interest therein.

9. Extras

Except as otherwise herein provided, no charge for any extra work or materials will be allowed unless the same has been ordered in writing by the Owner and either the price is stated in such order or a definite acknowledgment is made that a change in price is involved subject to later determination.

10. Changes in Work

- a. The Owner may at any time, by a written order, and without notice to the sureties, make changes in the drawings and specifications of this contract and within the general scope thereof. However, no change will be made which increases the total contract price without notice to sureties. In making any change, the charge or credit for the change shall be determined by the following method:
 - i. The actual cost of:
 1. Labor, including foreman
 2. Materials entering permanently into the work
 3. Equipment rental cost during time used on extra work
 4. Power and consumable supplies
 5. Insurance
 6. To the above cost there shall be added a fixed fee to be agreed upon, but not to exceed 15% of the net cost. This fee shall be compensation to cover the cost of supervision, overhead, bond, profit and other general expenses.

- b. The Contractor shall, when required by the Owner, furnish to the Owner an itemized breakdown of the quantities and prices used in computing the value of any change that might be ordered.
- c. In figuring changes, instructions for measurement of quantities set forth in the specifications shall be followed.
- d. If any part of the work as installed is at variance with the contract requirements, the Owner may, if he finds it to be in his interest, allow all or any part of such work to remain in place subject to a proper adjustment in the contract price.

11. Payment to Contractor

- a. Unless otherwise provided in the specifications, the Owner will make partial payments to the Contractor after receipt and approval of the request for partial payment covering the work performed during the preceding calendar month. No payments for installed materials on the site will be made unless such request is accompanied by a receipt or certification showing that the Contractor has made payment in full for such work done. In preparing such estimates, preparatory work done shall not be considered for payment. Materials delivered to site shall be considered for payment subject to the following conditions:
 - i. The material shall be kept in a safe and enclosed warehouse or area located on site with restricted access.
 - ii. The receipt and issue of material must be controlled by a stock card kept in the warehouse.
 - iii. Insurance coverage required under Chapter IV Section 11 of the General Conditions shall include insurance of such material and shall include theft insurance.
 - iv. Request for payment must be accompanied with certification and receipts indicating the cost of material and showing that Contractor has made full payment for such material.
- b. In making such partial payments there shall be retained ten percent (10%) of the estimated amount until final completion and acceptance of all work covered by the contract. However, if the Contracting Officer, at any time after 50 percent of the work has been completed, finds that satisfactory progress is being made, he may authorize payment in full of each progress payment for work performed beyond the 50 percent stage of completion. Also, whenever the work is substantially complete, the Contracting Officer, if he considers the amount retained to be in excess of the amount adequate for the protection of the Government, at his discretion, may release to the Contractor all or a portion of such excess amount.
- c. All materials and work covered by partial payments made shall thereupon become the sole property of the Owner, but this provision shall not be construed as relieving the Contractor from the sole responsibility for all materials and work upon which payment have been made, or the restoration of any damaged work or as a waiver of the right of the Owner to require the fulfillment of all of the terms of the contract.
- d. Release of Claims - Neither the final payment or any part of the retained percentage shall become due until the Contractor shall deliver to the Owner through the Contracting Officer a complete release of all claims against the Owner arising under and by virtue of this contract, including claims of all subcontractors and suppliers of either materials or labor, other than such claims, if any, as may be specifically excepted by the Contractor.
- e. Certificate of Completion - Upon completion and acceptance of all work whatsoever required and the release of all claims against the Owner as specified, the Contracting Officer shall file a written certificate with the Owner and with the Contractor as to the entire amount of work performed and compensation earned by the Contractor, including extra work and compensation therefore.

- f. Final Payment - Within thirty (30) calendar days after the filing of such certificate of completion, the Owner shall pay to the Contractor the amount therein stated less all prior payments and advances whatsoever to or for the amount of the contract. All prior estimates and payments including those relating to extra work shall be subject to correction by this payment which is throughout this contract called Final Payment.
- g. Acceptance of Final Payment Constitutes Release - The acceptance by the Contractor of the final payment shall be and shall operate as a release to the Owner of all claims and of all liability to the Contractor for all things done or furnished in connection with this work and for every act and neglect of the Owner and others relating to or arising out of this work, excepting the Contractor's claims for interest upon the final payments if this payment be improperly delayed. No payments, however, final or otherwise shall operate to release the Contractor or his sureties from any obligations under this contract or the performance and payment bonds.

MISCELLANEOUS

1. Prohibited Interests

- a. No member or employee of the Guam Legislature or Delegate to Congress, shall be admitted to any share or part of this contract or to any benefit that may arise there from, but this provision shall not be construed to extend to this contract if made with a corporation for its general benefit.
- b. No official or employee of the Government of Guam who is authorized in such capacity and on behalf of the Government to negotiate, make, accept or approve, or to take part in negotiating, making, accepting or approving any architectural, engineering, inspection, construction or material supply contract or any subcontract in connection with the construction of the project, shall become directly or indirectly interested personally in this contract or in any part hereof. No officer, employee, architect, attorney, engineer, or inspector of or for the Government of Guam authorized to exercise any legislative executive supervisory or other similar functions in connection with the construction of the project, shall become directly or indirectly interested personally in this contract or in any part thereof, any material supply contract, subcontract, insurance contract, or any other contract pertaining to the project.

2. Disputes

- a. The Port Authority of Guam and the Contractor agree to attempt resolution of all controversies which arise under, or are by virtue of, this procurement and any resulting contract through mutual agreement. If the controversy is not resolved by mutual agreement, then the Contractor shall request the government in writing to issue a final decision within sixty days after receipt of the written request. If the government does not issue a written decision within sixty days after written request for a final decision, or within such longer period as may be agreed upon by the parties, then the Contractor may proceed as though the government had issued a decision adverse to the Contractor.
- b. The Port Authority of Guam shall immediately furnish a copy of the decision to the Contractor, by certified mail with a return receipt requested, or by any other method that provides evidence of receipt.
- c. The Port Authority of Guam's decision shall be final and conclusive, unless fraudulent or unless the Contractor appeals the decision.
- d. This subsection applies to appeals of The Port Authority of Guam's decision on a dispute. For money owed by or to The Port Authority of Guam under this Agreement, the Contractor shall appeal the decision in accordance with the Government Claims Act by initially filing a claim with the Office of the Attorney General no later than eighteen months after the decision is rendered by The Port

Authority of Guam or from the date when a decision should have been rendered. For all other claims by or against The Port Authority of Guam arising under this Agreement, the Office of the Public auditor has jurisdiction over the appeal from the decision of the Port Authority of Guam. Appeals to the Office of the Public Auditor must be made within sixty days of the Port Authority of Guam's decision or from the date the decision should have been made.

- e. The Contractor shall exhaust all administrative remedies before filing an action in the Superior Court of Guam in accordance with applicable laws.
- f. The Contractor shall comply with the Port Authority of Guam's decision and proceed diligently with performance of the Agreement pending final resolution by the Superior Court of Guam of any controversy arising under, or by virtue of, the Agreement, except where the Contractor claims a material breach of the Agreement by *AGENCY*. However, if *AGENCY* determines in writing that continuation of services under the Agreement is essential to the public's health or safety, then the Contractor shall proceed diligently with performance of the Agreement notwithstanding any claim of material breach by *AGENCY*.

* * * * * **END OF GENERAL CONDITIONS** * * * * *

SPECIAL PROVISIONS

1. GENERAL INTENTION:

It is the declared intention and meaning to provide and secure all necessary labor, materials, equipment, tools and services necessary for the delivery and completion of the project identified in the bid documents and specifications provided herein.

2. BID:

The Contractor and each and every subcontractor shall read the General Conditions immediately following these special provisions, and by the act of submitting a bid, shall be deemed to have accepted all conditions contained therein.

3. SPECIFICATIONS AND STANDARDS:

The specifications and standards referenced in this specification (including addenda, amendments and errata listed) shall govern in all cases where the references thereto are made. In case of difference between the referenced specifications or standards and this specification or its accompanying drawings, this specification and its accompanying drawings shall govern to the extent of such difference, otherwise the referenced specifications and standards shall apply. Extra care shall be exercised to refer in requests for quotations in orders and in subcontracts to the referenced specifications and to all modifications thereof.

7. TIME FOR COMPLETION:

It is hereby understood and mutually agreed, by and between the Contractor and the Port Authority of Guam, that the date of beginning the project, rate of progress and the time for completion of the work to be done hereunder are essential conditions of this contract; and it is further mutually understood and agreed that the work embraced in this contract shall be commenced on a date to be specified in the Notice to Proceed and shall be completed within the specified date in the Notice to Proceed, unless otherwise adjusted by mutual agreement and corresponding contract modification.

5. LIQUIDATED DAMAGES:

It is hereby understood and mutually agreed by and between the Contractor and the Port Authority of Guam that liquidated damages shall be assessed for each calendar day the work remains incomplete after the days from the effective date set forth in the Notice to Proceed.

If the said Contractor shall neglect, fail or refuse to complete the work within the time herein specified, the Contractor does hereby agree, as part of the consideration for the awarding of this contract, to pay to the Port Authority of Guam the **amount of \$1,000.00** per calendar day, not as a penalty but as liquidated damages for such breach of contract as hereinafter set forth, for each and every calendar day that the Contractor shall be in default of the time stipulated in the contract for completing the work.

The said amount is fixed and agreed upon by and between the Contractor and the Port Authority of Guam because of the impracticability and extreme difficulty of fixing and ascertaining the actual damages the Port Authority of Guam would in such event sustain, and said amounts shall be retained from time to time by the Port Authority of Guam from current periodical estimates.

It is further agreed that time is of the essence of each and every portion of this contract, and of the specifications wherein a definite and certain length of time is fixed for the performance of any act whatsoever; and where under the contract an additional time is allowed for the completion of any work, the new time limit fixed by such extension shall be of the essence of this contract. Provided, that the Contractor shall not be charged with liquidated damages of any excess cost when the delay in completion of the work is due

- a. to any preference, priority or allocation order duly issued by the Port Authority of Guam.
- b. to unforeseeable causes beyond the control and without the fault or negligence of the Contractor, including but not restricted to acts of God or the public enemy, acts of the Port Authority of Guam, acts or another Contractor in the performance of a contract with the Port Authority of Guam, fires, floods, epidemics, quarantine restrictions, strikes, freight embargoes, and unusually severe weather; and
- c. to any delays of Subcontractors or suppliers occasioned by any of the causes specified in subsections (a) and (b) of this article.

Provided further that the Contractor shall, within seven (7) calendar days from the beginning of delay, give written notice as to the causes of the delay to the Contracting Officer, who will ascertain the facts and extent of the delay and notify the Contractor within reasonable time of his decision in the matter.

Contractor must note that Guam by nature has frequent rainfall causing suspension of work. Said suspensions shall not qualify for time extensions unless the weather is unusually severe.

6. DISPOSAL:

Unsuitable materials as a result of contractor's operations shall be disposed of in accordance with the local laws and/or policies of concerned agencies. Disposal, tipping fees/charges shall be at the contractor's expense.

The Contractor shall investigate the project site prior to bidding and verify existing conditions/ dimensions. Upon failure to do so any changes due to conditions/dimensions not reflected in the plans will be done at the Contractor's expense.

The Contractor shall submit technical brochures, samples, shop drawings and details as required by the Project Specifications prior to purchase or installation.

7. MATERIAL STANDARDS:

All material and equipment must conform to applicable standards of organizations such as the American National Standard Institute (ANSI), the American Society for Testing and Materials (ASTM), the National Manufacturers Association (NEMA), and the Underwriters Laboratories (UL). Proof of such conformance shall be submitted to the Engineer for approval. References to various standards contained in the specification and drawings shall be understood to be the issue or revision in effect on the date of such deviation shall be detailed in a written request to the Port Authority of Guam for approval and shall not be initiated until written approval is received by the Contractor from the Port Authority of Guam.

8. CONTRACTOR FURNISHED EQUIPMENT:

All materials and equipment required to complete the project shall be furnished by the Contractor.

9. OWNER FURNISHED MATERIALS:

If materials are provided by the Port Authority of Guam, the Contractor shall be responsible to transport these items from their current locations to the job site.

- a. The Contractor shall repair or replace these items if damaged during transport to the site. In addition, the Contractor shall repair any damage to public and private property caused by the transport of these items.
- b. All materials and equipment if furnished by the Port Authority of Guam are in good condition. Prior to the start of construction, the Contractor shall inspect these items and acknowledge the receipt thereof. The Contractor is responsible for repairing and replacing any damage or theft of equipment or damage which causes the equipment to be inoperable from the date it was received and prior to final acceptance of this project. All expenses shall be the Contractor's responsibility.

10. UNDERGROUND UTILITIES CLEARANCES IF APPLICABLE:

- a. The Contractor shall secure all permits required for construction including permits by the Department of Public Works, U.S. Navy, and other agencies involved.
- b. The Contractor shall coordinate with the government and private utility agencies in obtaining clearances prior to excavation. Extra care shall be taken so as not to damage any existing underground utilities. Any damaged utilities and any effects of the damage shall be the Contractor's responsibility.

11. SURPLUS MATERIALS:

Existing materials removed shall be cleaned, disassembled and assured to be in good condition before transporting the materials to the locations designated by the Contracting Officer. Materials returned shall be signed for receipt given. The Contractor shall be responsible for proper accounting of all returned materials. Any difference between the credit receipts and removal quantities, as determined by the Contracting Officer, shall be the Contractor's financial responsibility. The difference shall be deducted from the total value of the Contract at the end of the project. Unsalvageable, rotten or junk materials, must be certified by the Port Authority's Inspector in writing, and shall be properly disposed of at an approved disposal location at the sole financial responsibility of the Contractor

A. Definitions.

The definitions that apply to these COI Guidelines and the Port Authority of Guam's COI Disclosure Form are at the end of this document.

B. Required Disclosures.

Submittal of a Correct and signed COI Disclosure Form is required if any of the following apply (note that for the purposes of these COI Guidelines "Public Employee" includes all Port Authority of Guam employees):

- an Offeror or any of its Associates have any Apparent, Potential, or Actual Conflicts of Interest per these COI guidelines or per the criteria of any COI Form included as part of a Procurement or Contract;
- a Procurement or Contract document specifically requires submittal of a COI Disclosure Form (e.g., if the prospective Project includes preparation of an Environmental Impact Statement or Environmental Assessment, submittal of COI Disclosure Forms is always required.);
- an Offeror has any changes to its staffing or organization (whether before or after entering into a Contract) that result in an Apparent, Potential or Actual Conflict of Interest per these guidelines or per the criteria of any COI form associated with a particular Procurement or Contract. Any such changes shall be disclosed within 10 business days via submittal of a complete and signed COI Disclosure Form.
- the response to any of the following questions is "yes" (with respect to a Procurement or current Contract with Port Authority of Guam):
 1. Is any Associate of the Offeror a former employee of Port Authority of Guam (within the last year)?
 2. Is any Associate of the Offeror a Relative, Immediate Family Member, or Member of the Household of a current employee of Port Authority of Guam who had or may have a role in this Procurement, Authorization of the Contract, Contract administration, or oversight of the Contractor's performance?
 3. Does the Offeror or any Associate of the Offeror have an Actual, Apparent or Potential Conflict of Interest ("Individual" or "Organizational") with regard to any member of an Port Authority of Guam Procurement evaluation or selection team?

4. Did the Offeror or any Associate of the Offeror conduct prior work on the Project described in the Procurement, or participate in preparing any part of the Procurement or any documents or reports related to the Procurement or to which the Procurement refers?
5. Does the Offeror or any Associate of the Offeror have any past, present or currently planned interests which are an Actual, Apparent, or Potential Conflict of Interest (“Individual” or “Organizational”) with respect to performing the work for Port Authority of Guam?
6. Has the Offeror or an Associate of the Offeror offered to a Public Employee, or is the Offeror aware of any Public Employee that has solicited or received, directly or indirectly, any pledge or promise of employment or other benefit based on the understanding that the Public Employee’s vote, official action or judgment would be influenced thereby?
7. Has (or will) the Offeror or an Associate of the Offeror provided a direct beneficial financial interest to any person within one year after the person ceased to hold a position as a Public Employee who was involved in the Procurement or Authorization for the Contract, or is the Offeror aware of any such person or Public Employee who has or will receive a direct beneficial financial interest within the one-year period?
8. Is the Offeror aware of any current or former Public Employee that has an Actual, Apparent, or Potential Conflict of Interest with respect to the Procurement or award of this Contract or performing the work for Port Authority of Guam?
9. Does the prospective Contract include development of an environmental assessment (EA) or environmental impact statement (EIS)?
10. If a Procurement is to obtain personal services for the purpose of administering, managing, monitoring, inspecting, evaluating compliance with or otherwise overseeing a public contract, is the Offeror or an Associate or an Affiliate of the Offeror a party to the subject public contract?
11. Has the Offeror or any Associate of the Offeror entered into any contract(s) with Port Authority of Guam for the purpose of advising or assisting in developing any part of the solicitation documents, including specifications, requirements, a scope or statement of work, an invitation to bid, a request for proposals or other documents and materials used in, or related to this procurement?

If none of the foregoing apply, an Offeror shall provide a written and signed certification (specified by Port Authority of Guam) that the Offeror has read and complied with these COI Guidelines and the COI Disclosure Form and did not answer Yes to any of the questions, or, if required by the Port Authority of Guam, the Offeror shall complete and submit a Correct and signed COI Disclosure Form.

An Offeror shall incorporate in each required COI Disclosure Form any COI disclosure information provided by its staff and attach COI Disclosure Forms from each of its Subcontractors (that have required disclosures of conflicts or potential conflicts of interest), prior to such Offeror performing any services under a Contract.

The COI Disclosure Form is attached to the solicitation as a mandatory form that must be signed and submitted with Offeror’s Proposal.

C. Governing Standards.

Both Guam and federal laws govern disclosure and management of conflicts of interest in contracting processes. The disclosure requirements of these COI Guidelines apply to all Port Authority of Guam contracting activities {Architectural and Engineering (A&E) and non-A&E, public improvements, goods, and trade services} without regard to which particular federal or Guam laws govern the activity. There are also Standards of Conduct Policies for conflicts of interest regarding current Port Authority of Guam employees, and the employment of former Port Authority of Guam employees, which are applicable to this procurement, and are explained below.

STANDARDS OF CONDUCT POLICY REGARDING FORMER PORT AUTHORITY OF GUAM EMPLOYEES

When employees of firms which compete for or have Contracts with the Port Authority of Guam come to work for the Port Authority of Guam, and when Port Authority of Guam employees go to work for firms which compete for or have Contracts with the Port Authority of Guam, a Potential Conflict of Interest may exist.

Use of a former Port Authority of Guam employee by an Offeror on the same, or substantially similar Procurement, for which the employee performed a role or function for the Port Authority of Guam, unless mitigated to the satisfaction of the Port Authority of Guam, is prohibited for a period of one year following separation of employment with the Port Authority of Guam. Roles and functions of particular concern include drafting specifications or statements of work, reviewing or scoring a bid or proposal, authorizing service or assigning work, awarding a Contract, administering a Contract, or overseeing Contractor's performance. The Port Authority of Guam may determine that the role or Procurement is not substantially similar because of differences in location of the Project or work, because of the type and method of Procurement, because the employee did not participate personally or substantially in the procurement, because the role performed was minor in nature, such as a technical sufficiency review, or because the Civil Service Commission has granted the employee an applicable waiver. Examples of mitigation that may, in appropriate situations, be acceptable to the Port Authority of Guam include separation of certain decision-making functions concerning the Project, not using the employee in preparation of proposals but allowing them to perform work on the Project, and not having the employee have direct contact with Port Authority of Guam staff formerly under his/her supervision.

For each Procurement, Offerors shall disclose to Port Authority of Guam the identification of any of Offeror's employee(s) that had been employed by Port Authority of Guam within the twelve-month period prior to the submission date for the Proposal or bid. Each Offeror's disclosure shall include a signed statement by the former Port Authority of Guam employee of their proposed role for the Offeror in the particular Procurement and any resulting Contract. Failure of an Offeror to disclose such relationship or to remedy such potential violation will result in the rejection of the Offeror's bid or cancellation of the Contract with the Port Authority of Guam as well as being grounds for cancellation of an Offeror's prequalification or designation of an Offeror as ineligible for future Procurements as not being a responsible bidder. (Also see below regarding the ban on any direct beneficial or financial interest.)

Standards of Conduct Regarding Current Port Authority of Guam Employees Conflicts of Interest

The Guam Procurement Law statutory and regulatory framework, as generally applied, addresses conflicts of interest in public contracting by emphasizing the need for open and impartial Procurement methods and by prohibiting certain conflicts of interest involving public officials. The following statutes and administrative rules establish Guam's general policies and the restrictions and prohibitions regarding conflicts of interest for public contracts and Public Employees:

- The policies of the Guam Procurement Law (5 GCA § 5001, et seq) encourage public contracting competition that supports openness and impartiality to the maximum extent possible, while recognizing that the nature of effective and meaningful competition depends upon the service being procured.
- According to 5 GCA §§ 5001(b), 5003, and 5625, a sound and responsive public contracting system should instill public confidence through ethical and fair dealing, honesty, and good faith on the part of government officials and those who do business with the government.
- Article 11 of the Guam Procurement Law, Ethics in Public Contracting, and Article 2 of the Standards of Conduct for Elected Officers, Appointed Officers and Public Employees of the Government of Guam prohibit conflicts of interest of Public Employees and prohibit Public Employees from obtaining outside financial benefits for the exercise of their official duties. Among the prohibitions are offering a public employee a fee, a pledge of future employment, or anything valued in excess of \$200 based on an understanding that the offer would influence the public employee's official action or judgment.
- 5 GCA § 5632(a) provides the following: "Contemporaneous Employment Prohibited. Except as may be permitted by regulations pursuant to this Chapter or pursuant to Title 4 GCA, or rulings of the Civil Service Commission pursuant to this Chapter, it shall be a breach of ethical standards for any employee who is participating directly or indirectly in the procurement process to become or be, while such an employee, the employee of any person contracting with the governmental body by whom the employee is employed. Notice of this provision shall be provided in accordance with regulations promulgated by the Civil Service Commission."

- 5 GCA § 5632(c) and (d) provide the following: “(c) Disqualification of Business When an Employee Has a Financial Interest. It shall be a breach of ethical standards for a business in which an employee has a financial interest knowingly to act as a principal, or as an agent for anyone other than the Territory, in connection with any:

(1) judicial or other proceeding, application, request for a ruling or other determination;

(2) contract;

(3) claim; or

(4) charge or controversy; in which the employee either participates personally and substantially through decision, approval, disapproval, recommendation, the rendering of advice, investigation or otherwise, or which is the subject of the employee’s official responsibility, where the Territory is a party or has a direct and substantial interest.

D. Selling to the Territory After Termination of Employment is Prohibited. It shall be a breach of ethical standards for any former employee, unless the former employee’s last annual salary did not exceed Twelve Thousand Dollars (\$12,000.00), to engage in selling or attempting to sell supplies, services other than personal services, or construction to the Territory for ninety (90) days following the date employment ceased.

The term sell as used herein means signing a bid, proposal, or contract; negotiating a contract, contracting any employee for the purpose of obtaining, negotiating or discussing changes in specifications, price, cost allowances or other terms of a contract; settling disputes concerning performance of a contract; or any other liaison activity with a view toward the ultimate consummation of a sale although the actual contract therefor is subsequently negotiated by another person; provided, however, that this Section is not intended to preclude a former employee from accepting employment with private industry solely because the former employee’s employer is a contractor with this Territory, nor shall a former employee be precluded from serving as a consultant to this Territory.”

- 4 GCA § 15201 states: “No employee shall solicit, accept, or receive, directly or indirectly, any gift valued singly or in the aggregate from a single source in excess of \$200, whether in the form of money, prize, service, loan, travel, entertainment, hospitality, thing or promise, or in any other form, when a reasonable person would infer that the gift is intended to influence the employee in the performance of that individual's official duties or is intended as a reward for any official action on that individual's part.”
- 4 GCA § 15204 (a), (b), (c), and (d) provide: “No employee shall use or attempt to use an official position to secure or grant unwarranted privileges, exemptions, advantages, contracts, or treatment, for himself or herself, a spouse, children, or others, including but not limited to the following:
 - a. seeking other employment or contract for services by the use or attempted use of the individual's office or position;
 - b. accepting, receiving, or soliciting compensation for the performance of official duties or responsibilities except as provided by law;
 - c. using government time, equipment, or other facilities for private business purposes;
 - d. soliciting, selling, or otherwise engaging in a financial transaction with a subordinate or a person or business whom the employee inspects or supervises in official capacity.”
- 4 GCA § 15205 (a), (b), (c), (d), and (e) provide: “Conflicts of Interest.
 - a. No employee shall take any official action directly affecting:
 - 1. business or other undertaking in which the employee has a financial interest; or
 - 2. private undertaking in which the employee is engaged as legal counsel, advisor, consultant, representative, or other agency capacity. A department head who is unable to be disqualified on any matter described in item (1) or (2) of this Subsection may be in violation of this Subsection even if the individual has complied with the disclosure requirements of § 15208; and a person whose position on a board, commission or committee is mandated by statute, resolution or executive order to have particular qualifications shall only be prohibited from taking official action that directly and specifically affects a business or undertaking in which such person has a financial interest; provided that the financial interest is related to the member's particular qualifications.

- b. No employee shall acquire financial interests in any business or other undertaking which the employee has reason to believe may be directly involved in official action to be taken by the employee.
- c. No employee shall assist any person or business or act in a representative capacity before any territorial agency for any compensation in any transaction involving the Territory.
- d. No employee shall assist any person or business or act in a representative capacity for a fee or other compensation to secure passage of a bill or to obtain a contract, claim, or other transaction or proposal in which the employee has participated or will participate as an employee, nor shall the employee assist any person, or business, or act in a representative capacity for a fee or other compensation on such bill, contract, claim, or other transaction or proposal before the Legislature or territorial agency of which the individual is an employee.
- e. No employee shall assist any person or business or act in a representative capacity before a territorial agency for a fee or other compensation, on any bill, contract, claim, or other transaction or proposal involving official action by the agency if the employee has official authority over that agency unless such employee has complied with the disclosure requirements of § 15208.”

- 4 GCA § 15206 states: “Contracts.

(a) A territorial agency shall not enter into any contract with an employee or with a business in which an employee has a controlling interest, unless the contract has been awarded through an open, public process. A territorial agency may, however, enter into such contract without resort to competitive bidding process when, in the opinion of the General Services Agency or the procurement officer of that branch of government, the property or services does not fall within the purview of competitive bidding; provided that written justification for the non-competitive award of such contract be made a matter of public record and shall be filed with the Guam Ethics Commission at least ten (10) days before such contract is entered into. With regards to members of boards, commissions, and committees, this Subsection shall apply only to contracts entered into between a business in which a member has a controlling interest and a territorial agency in which the board, commission, or committee to which the individual is appointed has jurisdiction.

(b) A territorial agency shall not enter into a contract with any person or business which is represented or assisted in a material manner in the matter by a person who has been an employee of that agency within the preceding twelve (12) months and who participated while in 8 territorial office or employment in a material manner in the matter with which the contract is directly concerned.”

Port Authority of Guam’s COI Guidelines embody the intent of encouraging competition through openness, impartiality, and public disclosure of relevant information (and the avoidance of conflicts of interest) as described in Guam’s Procurement Law, Title 5, Chapter 5, Article 11, Ethics in Public Contracting; Title 4, Chapter 15, Standards of Conduct for Elected Officials, Appointed Officers, and Public Employees of the Government of Guam, The Guam Department of Administration Personnel Code of Conduct and Port Authority of Guam’s Standards of Conduct Policies or any other applicable governmental ethics policies.

The one-year prohibition against a Public Employee having a direct beneficial financial interest in a public contract as provided in 5 GCA § 5632(b) would generally preclude the person from working under the public contract and from representing the Offeror in dealings with the public agency for whom the person had worked. Sharing in the general profits of the Offeror (such as a year-end bonus for overall corporate profits) is likely not a direct beneficial financial interest, however, a bonus or other compensation paid just on the basis of the public contract would be subject to the prohibition.

STANDARDS OF CONDUCT FOR OFFERORS AND CONTRACTORS, AND ORGANIZATIONAL CONFLICTS OF INTEREST POLICY

It is the policy of Port Authority of Guam to avoid, neutralize, or mitigate organizational conflicts of interest that might exist for all procurements. Each individual contracting situation shall be examined on the basis of its particular facts and the nature of the proposed contract. The exercise of common sense, good judgment, and sound discretion is required in both the decision on whether a significant potential conflict exists and, if it does, the development of an appropriate means for resolving it. The principles underlying this policy are: (1) preventing the existence of conflicting roles that might bias an Offeror’s judgment; and (2) Preventing unfair competitive advantage. In addition to the other situations described in these COI Guidelines, an unfair competitive advantage exists where an Offeror competing for award of any Port Authority of Guam

contract possesses: (1) proprietary information that was obtained from a Public Employee without proper authorization; or (2) source selection information that is relevant to the contract but is not available to all competitors, and such information would assist that Offeror in obtaining the contract.

The following situations constitute organizational conflicts of interest. This listing is not exhaustive:

- A conflict of interest exists when an Offeror that provides systems engineering and technical direction for a system is awarded a contract to supply the system or any of its major components; or is a subcontractor or consultant to a supplier of the system or any of its major components; even if the Offeror did not have overall contractual responsibility for the system's development, its integration, assembly, and checkout, or its production. In this example, systems engineering includes a combination of substantially all of the following activities: determining specifications, identifying and resolving interface problems, developing test requirements, evaluating test data, and supervising design. Technical direction includes a combination of substantially all of the following activities: developing work statements, determining parameters, directing other contractors' operations, and resolving technical controversies. In performing these activities, a contractor occupies a highly influential and responsible position in determining a system's basic concepts and supervising their execution by other contractors. Therefore, this Offeror should not be in a position to make decisions favoring its own products or capabilities.
- A conflict of interest exists when an Offeror prepares and furnishes complete specifications covering non-developmental items, to be used in a competitive procurement, and submits a proposal or bid to be allowed to furnish these items, either as a prime contractor or as a subcontractor, for a reasonable period of time including, at least, the duration of the initial production contract.
- If a single contractor drafts complete specifications for non-developmental equipment, that contractor should be eliminated for a reasonable time from competition for production based on the specifications. This should be done in order to avoid a situation in which the contractor could draft specifications favoring its own products or capabilities. In this way the Government can be assured of getting unbiased advice as to the content of the specifications and can avoid allegations of favoritism in the award of production contracts.
- When an Offeror prepares, or assists in preparing, a statement of work, scope of services, or technical specifications to be used in competitively acquiring a system or services, or provides material leading directly, predictably, and without delay to such a statement of work, scope of services, or technical specifications, it is a conflict of interest if that Offeror submits a Proposal or bid to supply the system, major components of the system, or the services, unless:
 - (i) It is the sole source;
 - (ii) It has participated in the development and design work; or
 - (iii) More than one contractor has been involved in preparing the statement of work, scope of services, or technical specifications.
- Agencies should normally prepare their own statements of work, and scopes of services. When contractor assistance is necessary to prepare the statement of work or scope of services, the contractor is in a position to favor its own products or capabilities. To overcome the possibility of bias, Offerors are prohibited from supplying a system or services acquired on the basis of a statement of work or scope of services growing out of their services, unless:
 - (i) It is the sole source;
 - (ii) It has participated in the development and design work; or
 - (iii) More than one contractor has been involved in preparing the statement of work, scope of services, or technical specifications.
- It is a conflict of interest for a contractor to participate in the evaluation of products or services that it offers. Contracts for the evaluation of offers for products or services shall not be awarded to an Offeror that will evaluate its own offers for products or services, or those of a competitor.

The following situations are not considered to constitute organizational conflicts of interest. This list is not exhaustive:

- In development work, it is normal to select firms that have done the most advanced work in the field. These firms can be expected to design and develop around their own prior knowledge. Development contractors can frequently start production earlier and more knowledgeably than firms that did not participate in the development, and this can affect

the time and quality of production, both of which are important to the Government. In many instances the Government may have financed the development. Thus, while the development contractor has a competitive advantage, it is an unavoidable one that is not considered unfair; hence this is not considered an organizational conflict of interest.

- It is not an organizational conflict of interest for Offerors that furnish, at Government request, specifications or data regarding a product they provide, even though the specifications or data may have been paid for separately or in the price of the product.
- It is not an organizational conflict of interest where Offerors, acting as industry representatives, help Government agencies prepare, refine, or coordinate specifications, regardless of source, provided this assistance is supervised and controlled by Government representatives.

It is further the policy of Port Authority of Guam to restrict Offeror's use of confidential or proprietary information obtained from previous affiliations with the Port Authority of Guam or the Government when competing for Port Authority of Guam contracts. When a contractor requires proprietary information to perform a government contract and can use the leverage of the contract to obtain it, the contractor may gain an unfair competitive advantage unless restrictions are imposed. These restrictions protect the information and encourage companies to provide it when necessary for contract performance. They are not intended to protect information: (1) furnished voluntarily without limitations on its use; or (2) available to the Government or contractor from other sources without restriction.

In addition, a contractor that gains access to proprietary information of other companies in performing advisory and assistance services for the Government must agree with the other companies to protect their information from unauthorized use or disclosure for as long as it remains proprietary and refrain from using the information for any purpose other than that for which it was furnished. The Offeror shall provide Port Authority of Guam with copies of these agreements and ensure that they are properly executed.

Contractors also obtain proprietary and source selection information by acquiring the services of marketing consultants which, if used in connection with an acquisition, may give the contractor an unfair competitive advantage. Contractors should make inquiries of marketing consultants to ensure that the marketing consultant has provided no unfair competitive advantage, and must disclose these relationships to Port Authority of Guam on the COI Disclosure Form.

SPECIFIC FEDERAL STANDARDS—PROCUREMENTS RELATED TO DESIGN-BUILD AND DESIGN-BID-BUILD

Pursuant to 23 USC § 112(b)(3), the FHWA has promulgated administrative rules that affect federally funded Design-Build procurements and related procurements. These rules, which are in Chapter 23 of the CFR Part 636, are used as the basis for Port Authority of Guam's guidelines on the subject and specifically regulate both Organizational and Individual Conflicts of Interest. Port Authority of Guam's COI Guidelines incorporate a number of concepts from these federal provisions.

The primary rule governing Organizational Conflicts of Interest in Design-Build transactions is 23 CFR § 636.116. This rule affects not only Design-Build procurements, but also "any contract for engineering services, inspection or technical support in the administration of the Design-Build contract." Following is a summary of this federal rule (Port Authority of Guam's COI Guidelines apply this rule to design-bid-build and non-A&E activities as well):

Generally, a consultant who assists the state in preparing a Request for Proposals (RFP) document may not, subsequently, propose in response to the RFP. However, the state may determine that the consultant does not have a conflict of interest for a subsequent Procurement, if the consultant furnished only "low-level" documents that were incorporated into the RFP and made available to all offerors, and did not assist the state in the development of instructions to offerors or evaluation criteria for the RFP. These Design-Build regulations also apply to "improper business practices and personal conflicts of interest" of the Port Authority of Guam's selection team members. 23 CFR § 636.117 indicates that Federal Acquisition Regulations ("FARs"- specifically 48 CFR Part 3, Improper Business Practices and Personal Conflicts of Interest) will apply to the state's selection team members in the absence of relevant state laws and procedures. These regulations require government business to be "above reproach," conducted "with complete impartiality and with preferential treatment for none" and with "the highest degree of public trust and an impeccable standard of conduct" to avoid "even the appearance of a conflict of interest." In design-bid-build transactions, where engineering services are procured separately from the

construction services, ordinarily the consulting Offeror providing the engineering services is not eligible to bid on the construction work for the Project.

No Offeror or any Associate of an Offeror in connection with a Transportation Project shall have, directly or indirectly, any interest, other than his employment or retention by a State or other governmental instrumentality, in any Contract in connection with such Project. No firm or an Associate of an Offeror shall have, directly or indirectly, any interest in any real property acquired or to be acquired for a Project unless such interest is openly disclosed upon the records of Port Authority of Guam and such Offeror or Associate has not participated and will not participate in such acquisition for and in behalf of Port Authority of Guam (see 23 CFR § 1.33).

SPECIFIC FEDERAL STANDARDS - NATIONAL ENVIRONMENTAL POLICY ACT (NEPA)

No Offeror preparing or providing environmental analysis or impact documents relating to a Project, including draft and final Environmental Assessments (EA) or Environmental Impact Statements (EIS) may have a financial or other interest in the outcome of the Project. A financial or other interest in the outcome of the Project includes any known benefits other than general enhancement of professional reputation, and includes any agreement, enforceable promise, guarantee or expectation of future work on the Project as well as any indirect benefit the Offeror is aware of such as if the Project would aid proposals sponsored by the Offeror's other clients. Compliance with 40 C.F.R. 1506.5(c) is required, which includes the requirement for a conflict-of-interest disclosure statement from each Offeror establishing that the Offeror does not have a financial or other interest in the Project.

1. COI Considerations Related to Previous Work on Projects.

No Offeror that has previously performed services on behalf of Port Authority of Guam for a Project may be a Proposer or participate as an equity owner, team member, Subcontractor of or to a Proposer on the Project, or have a financial interest in any of the foregoing entities with respect to the Project, unless Port Authority of Guam is satisfied in its sole discretion that:

- (a) such services were completed prior to initiation of the Procurement for the Project (exceptions may apply for NEPA services on a case-by-case evaluation of the project specifics against the applicable CFRs);
- (b) such services included only Low-Level Documents and did not include development of instructions to offerors or evaluation criteria for the RFP;
- (c) such services did not provide the Offeror with access to or knowledge of Port Authority of Guam confidential or inside information that could provide an unfair competitive advantage with respect to the Procurement;
- (d) the prior Contract and information provided to the Offeror in the performance of its services are either irrelevant to the Procurement or are available on an equal and timely basis to all Proposers;
- (e) the work product from the Offeror incorporated into or relevant to the Procurement is available through Public Disclosure on an equal and timely basis to all Proposers; and
- (f) any environmental documents prepared by the Offeror have been determined to be objective, and that the Port Authority of Guam demonstrated independent decision-making authority during the environmental process.

In such instances where Port Authority of Guam is satisfied in the manner described above, Port Authority of Guam may still, in its sole discretion, restrict the scope of Procurement services for which the Offeror shall be eligible to perform in order to further the intent and goals of these COI Guidelines.

Public Disclosure of services or products is an important consideration in determining if an Organizational Conflict of Interest exists. All COI Disclosure Forms will be considered public records, as permitted under Guam's Procurement Law.

2. COI Disclosure Process.

An Offeror shall certify its compliance with these COI Guidelines at the time of submitting a Proposal to Port Authority of Guam, during the Procurement Process, and during the time of performance of any awarded Contract with Port Authority of Guam. If submittal of COI Disclosure Form(s) is required per these COI Guidelines or a specific Procurement or Contract, an Offeror shall represent the correctness of a completed COI Disclosure Form. If an Offeror has any changes to its staffing

or organization (whether before or after entering a Contract) that result in an Actual, Apparent or Potential Conflict of Interest (Individual or Organizational) per these COI Guidelines or per the criteria of any COI form associated with a particular Procurement or Contract, any such changes shall be disclosed within ten (10) business days via submittal of a Correct and signed COI Disclosure Form.

An Offeror shall assure that any COI Disclosure Form it submits includes any information required to be disclosed by its Subcontractors and other Associates, on behalf of the Offeror. An Offeror may submit either the Subcontractors' separate COI Disclosure Forms or incorporate Subcontractor information into its own COI Disclosure Form. The disclosure required with the proposal applies the prime and all proposed Subcontractors that are identified or anticipated at the time of proposal submission.

The identification, assessment, and management of Actual or Potential Conflicts of Interest are joint tasks among Port Authority of Guam, the Offeror and the Offeror's team. An Offeror must work together with Port Authority of Guam in an atmosphere of candor and accountability during the period of negotiation or performance of the Contract with Port Authority of Guam. Port Authority of Guam makes the final determination as to the adequacy of any COI disclosures or COI management plan offered by the Offeror.

Port Authority of Guam's COI determination is based on a number of factors such as:

- ✓ Situational Facts – description of the situation and all known facts specific to the actual or perceived COI
- ✓ Type of Work - specific product or service and Contract(s) involved
- ✓ Relationship to Management - specific interactions with Port Authority of Guam decision-makers
- ✓ Public Disclosure - timing and availability of product or service

The specific facts disclosed in any COI situation will be unique to that situation. Therefore, the decisions and conclusions reached in one situation may or may not be directly applicable to another. For example, the definition of "low-level" documents does not isolate an Offeror producing such documents from a potential COI situation. The ultimate determination will take into account the other factors described above.

3. Examples of Conflict-of-Interest Situations.

Port Authority of Guam offers the following examples to better illustrate conflict of interest situations that may arise during the course of the performance of a Personal Services Contract, Purchase Request, Purchase Order, or any Contract entered into between Port Authority of Guam and an Offeror, or during any Government of Guam Procurement process, in order to provide guidance to Offerors as they determine if their specific situations warrant disclosure, evaluation, and management.

- a. A Design-Build solicitation requires the responding teams to propose how to manage site features that were uncovered by a geotechnical engineering Offeror. The Offeror's reports to Port Authority of Guam on the Project are available to the public. A multi-specialty engineering Offeror that is the parent company of the geotechnical engineering Offeror submits a proposal to design the overall Project. Depending on the particular mitigating facts, Port Authority of Guam might determine in writing that the multi-specialty engineering Offeror is eligible to propose.
- b. Port Authority of Guam seeks comprehensive project management services for a series of Transportation Projects. One of the proposing Offerors employed a senior official from Port Authority of Guam who played a significant role in providing direction for the solicitation, six months ago. Port Authority of Guam initially assesses this situation as a potential Organizational Conflict of Interest and provides information to potential Proposers of this assessment through an addendum to the RFP. In its proposal, the Proposer provides mitigating information and written assurances that this individual works in an area of the company that will not be working on their program management proposal and that the individual will be isolated inside the company from any information associated with the program, will not be lobbying Port Authority of Guam, will not engage in any activities that would violate the Port Authority of Guam Code of Conduct Policy for the prescribed one-year period, and for a period of one year will not have a direct beneficial interest in the contract. Depending on the particular facts, Port Authority of Guam might determine that, while the proposing Offeror has a potential Organizational Conflict of Interest, that conflict has been adequately mitigated and the Offeror will not be disqualified from submitting a proposal.
- c. Port Authority of Guam issues an RFP for design and oversight of an intelligent system to collect bridge tolls. The RFP provides that companies having a financial interest in the relevant telecommunications hardware will be excluded from bidding. A company under common ownership with a major electronics manufacturer desire to bid.

Port Authority of Guam initially assesses this situation as an Organizational Conflict of Interest, because it cannot know in advance whether the hardware products of this electronics manufacturer would be used in the Project, and Port Authority of Guam informs potential Proposers of its concern related to this type of conflict via addendum to the RFP. In its proposal, the company offers no mitigating facts or organizational plans that address Port Authority of Guam's concerns about the conflict. Depending on the particular facts, Port Authority of Guam determines that the company has an actual conflict of interest.

- d. Port Authority of Guam seeks advice of an industry advisory committee to formulate the specifications for an information technology (IT) RFP. An IT Offeror that participated in the advisory committee wishes to submit a proposal in response to the RFP. Depending on the particular facts, Port Authority of Guam might determine that the role of the Offeror was to represent the industry in the context of a public meeting where other Offerors were invited to submit comments, and that the Offeror therefore does not have an Organizational Conflict of Interest.
- e. Port Authority of Guam contracts with an A&E Offeror to develop "low-level" documents prior to establishing a schedule for an RFP in which the "low level" documents, still under development, will be used by prospective Proposers. The A&E Offeror has attended the pre-proposal meeting and wishes to propose on the RFP. Port Authority of Guam determines that the company has a potential Organizational Conflict of Interest because of the fact that the low-level documents have not been made public and the Offeror will still be developing the documents during the solicitation. The company then mitigates the potential conflict of interest by suspending development of new reports during the open period of the solicitation and making all data and information sources available on a Port Authority of Guam website prior to the RFP release. Port Authority of Guam determines that the potential conflict has been adequately managed and the Offeror will not be disqualified from submitting a proposal or being part of the proposing team.
- f. Port Authority of Guam contracts with a consulting Offeror to assist Port Authority of Guam in the development of an RFP and sample Contract for a Design-Build Procurement for construction of certain Transportation Projects. The Offeror has close contact with Port Authority of Guam decision-makers in the development of the evaluation criteria for the RFP and the proposed Contract terms, and that information is shared throughout the Offeror with all management and technical personnel. The Offeror will not be able to submit a proposal in the design-build Procurement, or participate as a team member with an Offeror submitting a proposal in response to the RFP.
- g. Port Authority of Guam seeks comprehensive program management services for a series of Transportation Projects. Prior to release of the RFP, Port Authority of Guam shared its interpretation of the applicable conflict of interest requirements with the industry. One of the proposing Offerors has a related entity with a planned interest in future design-build construction work related to the transportation program. The COI Disclosure Form does not clearly state whether the related entity is a subsidiary, major partner, Subcontractor, or affiliate of a Subcontractor. The proposing Offeror describes its intent to restrict the flow of information concerning construction Projects to the related entity and thereby to its affiliate construction company but does not clarify how much information will be shared between the principal and its Subcontractors and affiliates or the controls placed on the principal Subcontractor-affiliate relationship. Furthermore, the proposing Offeror has provided mitigation information, indicating that the related entity will not participate in providing services under the program management Contract (i.e., design, source selection, award of Contract, etc.). Port Authority of Guam may conclude the proposing Offeror does not have a conflict of interest that detracts from its eligibility for the program management award. Port Authority of Guam may determine that the related entity has a conflict of interest in future design-build construction work related to the bridge repair and replacement program that has not been adequately mitigated by the measures and information provided by the proposing Offeror. As a result, if the proposing Offeror is awarded the program management Contract, the related construction company will be ineligible for construction work under the program. This determination will depend upon the precise relationship between the related entity and the Proposer.
- h. Completion of a project may encourage construction of a shopping center or industrial park from which an Offeror stands to benefit. If an Offeror is aware that it has such an interest in the decision on the proposal, it will be disqualified from preparing an EIS to preserve the objectivity and integrity of the NEPA process.
- i. Port Authority of Guam issues an RFP for A&E services to prepare plans, specifications, and estimate (PS&E) to replace a bridge. The PS&E will be completed as part of a design-bid-build process. One of the A&E firms proposing on the design services owns XYZ Inc., a subsidiary that provides program management services to Port Authority of

Guam under a separate contract. Port Authority of Guam's intent, as advertised in the RFP, is to use XYZ Inc. for administration and oversight of the A&E design services for the bridge replacement project. The A&E firm that is the parent of XYZ Inc. would be ineligible for award of the A&E design contract.

- j. Port Authority of Guam issues an IFB for construction services to replace a bridge. The replacement is being done using the design-bid-build process. One of the construction firms bidding on the public improvement project owns XYZ Inc., a subsidiary that provides construction contract administration and inspection services to Port Authority of Guam under a separate contract. Port Authority of Guam's intent, as advertised in the IFB, is to use XYZ Inc. for administration and inspection of the bridge replacement project. The construction firm that is the parent of XYZ Inc. would be ineligible for award of the construction contract.

DEFINITIONS

The following definitions apply to these COI Guidelines and the Port Authority of Guam's COI Disclosure Form:

"Actual Conflict of Interest" means that an individual or Offeror is unable to render impartial assistance or advice to Port Authority of Guam, has impaired objectivity in performing the Project work, or has an unfair competitive advantage. "Actual Conflict of Interest" means any action or any decision or recommendation by a person acting in a capacity as a public official, the effect of which would be to the private pecuniary benefit or detriment of the person or the person's relative or any business with which the person or a relative of the person is associated unless the pecuniary benefit or detriment arises out of the circumstances described in the definition for "Potential Conflict of Interest" (see definition below).

"Affiliate" (of an Offeror) means a person or entity that, directly or indirectly through one or more intermediaries, controls, is controlled by, or is under common control of the Offeror.

"Apparent Conflict of Interest" means that an individual or Offeror may reasonably be perceived to have an Actual Conflict of Interest or a Potential Conflict of Interest.

"Associate" (of the Offeror) means an employee, executive, director, key project personnel, consultant, contractor, or Subcontractor, or any immediate family member of the foregoing.

"Authorization" (of the Contract). A public contract is authorized by a Public Employee if the Public Employee participated substantially in the procurement selection process or performed a significant role in the selection of an Offeror or the execution of the Contract. A significant role includes recommending approval or signing of the Contract, including serving as a reference, recommending selection or serving on a selection committee or team, or having the final authorizing authority for the Contract.

"Bidder" means a legally operating business entity submitting a bid in response to a Procurement solicitation.

"Conflict of Interest" or "COI" means an Individual Conflict of Interest or Organizational Conflict of Interest and includes an Actual, Potential, or Apparent Conflict of Interest.

"COI Disclosure Form" means a manually signed disclosure of any Actual Conflict of Interest, Apparent Conflict of Interest or Potential Conflict of Interest documented in the form of Port Authority of Guam's COI Disclosure Form.

"COI Guidelines" refers to this document and all references herein.

"Contract" means an Agreement, Contract, Purchase Request (PR), Work Order Contract (WOC), Purchase Order (PO), or any other type agreement with Port Authority of Guam, regardless of what it may be called, for the procurement or disposal of supplies, services, or construction.

"Contractor" means a legally operating business entity that has been awarded a contract in response to a Procurement.

"Correct" means, in the context of determining the accuracy of a COI Disclosure Form, that the form, in all material respects, is complete, accurate, not misleading, and does not omit any material information.

"Immediate Family Member" (of the Public Employee) means a spouse, children, parents, brothers and sisters, grandparents and grandchildren, mothers-in-law and fathers-in-law, brothers-in-law and sisters-in-law, daughters-in-law and sons-in-law. Stepsiblings, stepchildren and stepparents shall also be regarded as immediate family.

"Individual Conflict of Interest" means that an individual has a conflict of interest because of a financial interest, gift, or other activities or relationships with other persons including but not limited to individuals with whom the individual has business, familial or household relationships.

"Interest" (in the context of a conflict of interest) means a direct or indirect interest and includes a personal as well as financial interest.

“Low-Level Document” means A&E, non-A&E and IT program or Project-related documents which provide a basic understanding of a specific aspect of the program or Project. With regard to A&E and related services, it means that the role of the consultant or subconsultant was limited to provision of preliminary design, reports, or similar “low-level” documents that will be incorporated into the solicitation, and did not include assistance in development of instructions to offerors or evaluation criteria.

“Member of the Household” (of the Public Employee) means any person who resides with the Public Employee.

“Offeror” means a Proposer or Bidder under a Procurement solicitation, a consultant or contractor under a Contract, or a Subcontractor at any tier of a Proposer, consultant, or contractor, and any partner or member of any of the foregoing. An Offeror includes all persons, individual or corporate, without regard to form of legal entity, and any partner or member of any of the foregoing.

“Organizational Conflict of Interest” means that a relationship or situation exists whereby an Offeror or any of its Associates has past, present, or currently planned interests or activities that either directly or indirectly (through a client, contractual, financial, organizational or other relationship) may relate to the work to be performed under the proposed Contract with Port Authority of Guam and which: (a) diminish the Offeror’s or an Associate’s capacity to give impartial, technically sound, objective assistance or advice; (b) may impair the Offeror’s or an Associate’s objectivity in performing the Contract; (c) may impair Port Authority of Guam’s objectivity in oversight of the Contractor’s performance; or (d) may result in an unfair competitive advantage. It does not include the normal flow of benefits from the performance of the Contract.

“Potential Conflict of Interest” means that an individual or Offeror, as a result of current plans, may reasonably be expected to have an actual conflict of interest. “Potential Conflict of Interest” means any action or any decision or recommendation by a person acting in a capacity as a public official, the effect of which could be to the private pecuniary benefit or detriment of the person or the person’s relative, or a business with which the person or the person’s relative is associated, unless the pecuniary benefit or detriment arises out of the following: (a) an interest or membership in a particular business, industry, occupation or other class required by law as a prerequisite to the holding by the person of the office or position; (b) any action in the person’s official capacity which would affect, to the same degree, a class consisting of all inhabitants of the state or a smaller class consisting of an industry, occupation or other group including one of which or in which the person, or the person’s relative or business with which the person or the person’s relative is associated, is a member or is engaged; or (c) membership in or membership on the board of directors of a nonprofit corporation that is tax-exempt under section 501(c) of the Internal Revenue Code.

“Procurement” means a Request for Proposals (RFP), Request for Quotes (RFQ), Request for Information (RFI), Invitation for Bid (IFB), or any other form of solicitation or Procurement by Port Authority of Guam.

“Project” means any proposed or existing undertaking pertaining to such programs that are assigned to Port Authority of Guam under applicable law.

“Proposal” means a bid, proposal, or other submission appropriate to a Procurement.

“Proposer” means a legally operating business entity submitting a Proposal in response to a Procurement.

“Public Disclosure” means the work product or service (in connection with the preparation of a Procurement) is available for public review and analysis for a reasonable amount of time, typically at least thirty (30) calendar days.

“Public Employee” means any person who is serving the government of Guam or any of its political subdivisions or any other governmental body as defined in 5 GCA § 5125 as an elected official, appointed official, employee, agent, or otherwise, irrespective of whether the person is compensated for the services. (For the purposes of these COI Guidelines, all Port Authority of Guam employees are considered Public Employees under this definition.)

“Relative” (of a Public Employee) means:

- any individual who is related to the public official as father, mother, son, daughter, brother, sister, uncle, aunt, first cousin, nephew, niece, husband, wife, father-in-law, mother-in-law, son-in-law, daughter-in-law, brother-in-law, sister-in-law, stepfather, stepmother, stepson, stepdaughter, stepbrother, stepsister, half-brother, or half-sister; or
- any individual for whom the Public Employee has a legal support obligation or for whom the Public Employee provides benefits arising from the Public Employee’s public employment or from whom the Public Employee receives benefits arising from that individual’s employment.

“Subcontractor” means a contractor or subcontractor at any tier lower than the awarded Contractor.

The non-Federal entity must maintain written standards of conduct covering conflicts of interest and governing the actions of its employees engaged in the selection, award and administration of contracts. No employee, officer, or agent may participate in the selection, award, or administration of a contract supported by a federal award if he or she has a real or apparent conflict of interest. Such a conflict of interest would arise when the employee, officer, or agent, any member of his or her immediate family, his or her partner, or an organization which employs or is about to employ any of the parties indicated herein, has a financial or other interest in or a tangible personal benefit from a firm considered for a contract. The officers, employees, and agents of the non-Federal entity may neither solicit nor accept gratuities, favors, or anything of monetary value from contractors or parties to subcontracts. However, non-Federal entities may set standards for situations in which the financial interest is not substantial or the gift is an unsolicited item of nominal value. The standards of conduct must provide for disciplinary actions to be applied for violations of such standards by officers, employees, or agents of the non-Federal entity.

VOLUME 3
REQUIRED FORMS AND AFFIDAVITS



INVITATION FOR BID (IFB) No. PAG-CIP-024-003

Project title:

WAREHOUSE 1 ROOF VENT REPLACEMENT PROJECT

SPECIAL REMINDER TO PROSPECTIVE BIDDERS

Bidders are reminded to read the Instructions to Bidders attached to ascertain that all of the following requirements checked below are submitted in the bid envelope, **one (1) original, two (2) copies, one (1) CD or USB containing electronic file copy of all documents to be submitted**, at the date and time for it is due.

- COMPETENCY OF BIDDERS REQUIREMENTS (Refer to Section II.13 of Vol. I)
- BID FORM and BID SCHEDULE
- BID SECURITY (15% of the bid)
- AFFIDAVIT DISCLOSING OWNERSHIP AND COMMISSIONS (*AG Form 002*)
- AFFIDAVIT RE NON-COLLUSION (*AG Form 003*)
- AFFIDAVIT RE NO GRATUITIES OR KICKBACKS (*AG Form 004*)
- AFFIDAVIT RE ETHICAL STANDARDS (*AG Form 005*)
- DECLARATION RE COMPLIANCE WITH U.S. DOL WAGE DETERMINATION (*AG Form 006*)
- AFFIDAVIT RE CONTINGENT FEES (*AG Form 007*)
- RESTRICTION AGAINST SEX OFFENDERS EMPLOYED BY SERVICE PROVIDERS TO GOVERNMENT OF GUAM FROM WORKING ON GOVERNMENT PROPERTY
- BYRD ANTI-LOBBYING CERTIFICATION
- CONFLICT OF INTEREST FORM
- OTHER REQUIREMENTS: (a) Valid Copy of Contractor's License or (b) Business License whichever is applicable; upon request; prior to Award.**

This reminder must be signed and included in the BID envelope. **Failure to comply with the above requirements will mean a disqualification and rejection of the proposal.**

On this ____ day of _____ 20____, I, _____, authorized representative of _____, acknowledge receipt of this Special Reminder to Prospective Bidders for the above referenced IFB and hereby attest that I have read and understand its intent and implications.

Signature of Authorized Representative

THIS REMINDER FORM MUST BE COMPLETED AND RETURNED IN THE ENVELOPE CONTAINING THE BID.

Rev.10/95

BID FORM

Date: _____

To: General Manager
Port Authority of Guam
1026 Cabras Highway, Suite 201
Piti, Guam 96915

Gentlemen:

The undersigned (hereafter called the Bidder), a _____

(Corporation, Partnership or Individual)

organized and/or licensed to do business under the laws of _____, hereby proposes and agrees to furnish all of the necessary labor, materials, equipment, tools and services necessary for **IFB-PAG-CIP-024-003 WAREHOUSE 1 ROOF VENT REPLACEMENT** all in accordance with the drawings, specifications and other contract documents prepared by the Port Authority of Guam for the sum of _____ US Dollars (\$ _____) plus any and all sums to be added and/or deducted resulting from all extra and/or omitted work in accordance with the unit and/or lump sum prices stated in the itemized bid form attached hereto.

The undersigned has examined the location of the proposed work, the drawings, specifications and other contract documents and is familiar with the local conditions at the place where the work is to be performed.

The bid security attached, without endorsement, in the sum of not less than fifteen percent (15%) of the amount of the bid, is furnished to the Government as a guarantee that the contract will be executed and a performance and payment bond furnished within ten (10) working days after the acceptance of the bid of the undersigned. In the event that the undersigned bidder shall fail to execute the contract and furnish a satisfactory performance and payment bond under the conditions and within the time specified in this bid, the bid security shall be forfeited as liquidated damages for the delay and additional work and costs caused thereby in obtaining another bidder. The undersigned hereby agrees that the amount of the attached bid security is a reasonable forecast of potential damages and is not a penalty.

If written notice of the acceptance of this bid is mailed, telegraphed or delivered to the undersigned within sixty (60) calendar days after the opening thereof, the undersigned agrees to execute the form of agreement included as one of the contract documents, and to furnish a performance and payment bond in an amount equal to one hundred percent (100%) of the contract amount within ten (10) working days after receipt of such notice.

The undersigned hereby acknowledges receipt of the following addenda:

ADDENDUM NO.	DATED

If awarded the contract, the undersigned agrees to complete the work within the required contract period as defined in the bid documents. The undersigned understands that the Port Authority of Guam reserves the right to reject any or all bids or to waive any informality or technicality in any bids in the interest of the Government.

Attached hereto is an affidavit as proof that the undersigned has not engaged into any collusion with any person with respect to this bid or any other bid or the submitting of bids for the contract for which this bid is submitted.

RESPECTFULLY SUBMITTED BY:

(CONTRACTOR)

(BY)

(TITLE)

(BUSINESS ADDRESS)

BID BOND

BOND NO. _____

KNOW ALL MEN BY THESE PRESENTS, that _____
(Name of Contractor)

as Principal, hereinafter called the Principal and _____
(Name of Surety)

a duly admitted insurer under the laws of Guam, as Surety, hereinafter called the Surety, are held and firmly bound unto the Port Authority of Guam for the sum of _____ Dollars (\$ _____), for payment of which sum will and truly to be made, the said Principal and the said Surety bind ourselves, our heirs, executors, administrators, successors and assigns, jointly and severally, firmly by these presents.

WHEREAS, the Principal has submitted a bid for **IFB-PAG-CIP-024-003 WAREHOUSE 1 ROOF VENT REPLACEMENT PROJECT.**

NOW THEREFORE, if the Port Authority of Guam shall accept the bid of the Principal and the Principal shall not withdraw said bid within sixty (60) calendar days after the opening of bids, and shall within ten (10) working days after the prescribed forms are presented to him for signature, enter into a Contract with the Port Authority of Guam in accordance with the terms of such bid and give such bond or bonds as may be specified in the bidding or Contract Documents with good and sufficient surety for the faithful performance of such Contract and for the prompt payment of labor and material furnished in the prosecution thereof, or in the event of the failure of the Principal to enter into such Contract and give such bond or bonds, if the Principal shall pay to the Port Authority of Guam the difference, not to exceed the amount hereof, between the amounts specified in said bid and such larger amount for which the Port Authority of Guam may in good faith contract with another party to perform work covered by said bid or an appropriate liquidated amount as specified in the Invitation for Bids then this obligation shall be null and void, otherwise to remain in full force and effect.

Signed and sealed this _____ day of _____ 20____

(PRINCIPAL)

(SEAL)

(WITNESS)

(TITLE)

(MAJOR OFFICER OF SURETY)

(MAJOR OFFICER OF SURETY)

(TITLE)

(TITLE)

(RESIDENT GENERAL AGENT)

**AFFIDAVIT DISCLOSING OWNERSHIP, INFLUENCE, COMMISSIONS AND
CONFLICTS OF INTEREST**

(Required by 5 GCA § 5233 as amended by P.L. 36-13 (4/9/2021))

CITY OF _____)
) ss.
 ISLAND OF GUAM)

Preface. As a condition of submitting a Bid/Offer/Proposal or responding to any method of source selection under Guam’s Procurement Law for the purpose of entering into a contract with the government of Guam, this Affidavit requires all Bidders/Offerors/Prospective Contractors to make disclosures of ownership, influence, commissions, gratuities, kickbacks, and conflicts of interest occurring **during the 365 calendar days preceding the publication of this solicitation and until award of a contract**. This includes the duty to disclose **any changes** to the facts disclosed herein throughout the solicitation process; and if the entity submitting this Affidavit is awarded a contract, the duty to disclose **any changes** to the facts disclosed herein **continues throughout the life of the contract, including any extensions or renewals**.

A. I, the undersigned, being first duly sworn, depose and say that I am an authorized representative of the Bidder/Offeror/Prospective Contractor and that (please check and fill out all that apply):

[] The Bidder/Offeror/Prospective Contractor is an individual with a business license, and all decisions are by, and all profit is for, that same individual, with principal place of business street address being:_____

[] The Bidder/Offeror/Prospective Contractor is a business or artificial person (as defined in 1 GCA § 715 or 5 GCA §§ 5030(n) or 5233(b)), and is a sole proprietorship owned entirely (100%) by_____, with principal place of business street address being:_____

[] The Bidder/Offeror/Prospective Contractor is a business or artificial person (as defined in 1 GCA § 715 or 5 GCA §§ 5030(n) or 5233(b)), and is owned by the following multiple individuals. Note: owners of more than 10% are statutorily required to be listed below, but other owners of smaller percentage are encouraged to be listed as well.

Name of Owner	Principal Place of Business Street Address	% of Interest
_____	_____	_____
_____	_____	_____
_____	_____	_____
_____	_____	_____

[] One or more of the more-than-10% owners listed above is a business or artificial person. Any more-than-25% owners of such a business or artificial person are listed below per 5 GCA § 5233. Note: any less-than-25% owners of such a business or artificial person is encouraged to also be listed below.

Name of >10% Owner Business or Artificial Person:

--

Names of owners of the >10% Owner Business or Artificial Person ("Second Tier Owner")	Owner's Principal Place of Business Street Address	% of Interest

Name of other >10% Owner Business or Artificial Person:

--

Names of owners of the >10% Owner Business or Artificial Person ("Second Tier Owner")	Owner's Principal Place of Business Street Address	% of Interest

B. If any Second Tier Owner identified above is an artificial person, the natural or artificial owners of such Second Tier Owner who have held more than 49% of the shares or interest in the Bidder/Offeror/Prospective Contractor (Third Tier Owners) are as follows [if none, please so state]:

Second Tier Owner Name _____

Name of Third Tier Owner	Principal Place of Business Street Address	% of Interest
_____	_____	_____
_____	_____	_____
_____	_____	_____
_____	_____	_____

C. If the name of no natural person has been identified as an owner, or a Second or Third Tier Owner of the Bidder/Offeror/Prospective Contractor, please identify the name, position, address, and contact information of the natural person having the authority and responsibility for the Bid/Offer/Proposal/Prospective Contract, and the name of any natural person who has the authority and power to remove and replace the designated responsible person:

Name of Natural Person	Position	Street Address of Principal Place of Business	Phone Number, Email Address, and other Contact Information

D. Further, I say that the persons who have received or are entitled to receive a commission, gratuity, contingent fee or other compensation to solicit, secure, or assist in obtaining business related to the Bid/Offer/Proposal/Prospective Contract for which this Affidavit is submitted are as follows (if none, please so state):

Name	Principal Place of Business Street Address	Amount of Compensation
_____	_____	_____
_____	_____	_____

E. Further, I say that the persons who have directly or indirectly participated in this solicitation and who are also employees of the government of Guam or the government of the United States, if federal funds are to be used in the payment of the contract related to the Bid/Offer/Proposal/Prospective Contract for which this Affidavit is submitted, are as follows (if none, please so state):

Name	Principal Place of Business Street Address
_____	_____
_____	_____

F. Regardless of any ownership interest, the following individuals have the power to control the performance of the contract or to control the Bidder/Offeror/Prospective Contractor, directly or indirectly:

Name	Principal Place of Business Street Address
_____	_____
_____	_____

G. Until award of the contract, and throughout the term of any contract awarded to the Bidder/Offeror/Prospective Contractor represented herein, I agree to promptly make any disclosures not made previously and update changes in ownership, identities of owners and other required information, interests, compensation or conflicts of the persons required to be disclosed. I understand that failure to comply with this requirement shall constitute a material breach of contract.

H. I hereby declare under penalty of perjury under the laws of Guam that the foregoing is true and correct.

Executed on: _____
(date)

Signature of one of the following:

Bidder/Offeror/Prospective Contractor, if a licensed individual
Owner of sole proprietorship Bidder/Offeror/Prospective Contractor
Partner, if the Bidder/Offeror/Prospective Contractor is a partnership
Officer, if the Bidder/Offeror/Prospective Contractor is a corporation

Subscribed and sworn to before me

This ____ day of _____, 20 ____.

NOTARY PUBLIC

My commission expires: _____

AFFIDAVIT re NON-COLLUSION

CITY OF _____)
) ss.
ISLAND OF GUAM)

_____ [state name of affiant signing below], being first duly sworn, deposes and says that:

1. The name of the offering company or individual is [state name of company]

_____.

2. The proposal for the solicitation identified above is genuine and not collusive or a sham. The offeror has not colluded, conspired, connived or agreed, directly or indirectly, with any other offeror or person, to put in a sham proposal or to refrain from making an offer. The offeror has not in any manner, directly or indirectly, sought by an agreement or collusion, or communication or conference, with any person to fix the proposal price of offeror or of any other offeror, or to fix any overhead, profit or cost element of said proposal price, or of that of any other offeror, or to secure any advantage against the government of Guam or any other offeror, or to secure any advantage against the government of Guam or any person interested in the proposed contract. All statements in this affidavit and in the proposal are true to the best of the knowledge of the undersigned. This statement is made pursuant to 2 GAR Division 4 § 3126(b).

3. I make this statement on behalf of myself as a representative of the offeror, and on behalf of the Offeror's officers, representatives, agents, subcontractors, and employees.

Signature of one of the following:
Offeror, if the offeror is an individual;
Partner, if the offeror is a partnership;
Officer, if the offeror is a corporation.

Subscribed and sworn to before me
this ____ day of _____, 20 ____.

NOTARY PUBLIC
My commission expires _____, ____.

DECLARATION RE COMPLIANCE WITH U.S. D.O.L. WAGE DETERMINATION

Procurement No: IFB-PAG-CIP-024-002 WELDER'S SHOP REPAIR AND UPGRADES

Name of Offeror Company: _____ hereby certifies under penalty of perjury:

(1) That I am _____ (the offeror, a partner of the offeror, an officer of the offeror) making the bid or proposal in the foregoing identified procurement;

(2) That I have read and understand the provisions of 5 GCA § 5801 and § 5802 which read:

§ 5801. Wage Determination Established.

In such cases where the government of Guam enters into contractual arrangements with a sole proprietorship, a partnership or a corporation ("contractor") for the provision of a service to the government of Guam, and in such cases where the contractor employs a person(s) whose purpose, in whole or in part, is the direct delivery of service contracted by the government of Guam, then the contractor shall pay such employee(s) in accordance with the Wage Determination for Guam and the Northern Mariana Islands issued and promulgated by the U.S. Department of Labor for such labor as is employed in the direct delivery of contract deliverables to the government of Guam.

The Wage Determination most recently issued by the U.S. Department of Labor at the time a contract is awarded to a contractor by the government of Guam shall be used to determine wages, which shall be paid to employees pursuant to this Article. Should any contract contain a renewal clause, then at the time of renewal adjustments, there shall be made stipulations contained in that contract for applying the Wage Determination, as required by this Article, so that the Wage Determination promulgated by the U.S. Department of Labor on a date most recent to the renewal date shall apply.

§ 5802. Benefits.

In addition to the Wage Determination detailed in this Article, any contract to which this Article applies shall also contain provisions mandating health and similar benefits for employees covered by this Article, such benefits having a minimum value as detailed in the Wage Determination issued and promulgated by the U.S. Department of Labor, and shall contain provisions guaranteeing a minimum of ten (10) paid holidays per annum per employee.

(3) That the offeror is in full compliance with 5 GCA § 5801 and § 5802, as may be applicable to the procurement referenced herein;

(4) That I have attached the most recent wage determination applicable to Guam issued by the U.S. Department of Labor. [INSTRUCTIONS – Please attach!]

Signature _____ Date _____

**"REGISTER OF WAGE DETERMINATIONS UNDER | U.S. DEPARTMENT OF LABOR THE SERVICE CONTRACT ACT| EMPLOYMENT STANDARDS ADMINISTRATION
By direction of the Secretary of Labor | WAGE AND HOUR DIVISION | WASHINGTON D.C. 20210 | Wage Determination No.: 2015-5693 Daniel W. Simms
Division of | Revision No.: 20 Director Wage Determinations | Date of Last Revision: 12/26/2023**

Note: Contracts subject to the Service Contract Act are generally required to pay at least the applicable minimum wage rate required under Executive Order 14026.

|If the contract is entered into on or |Executive Order 14026 generally applies to | after January 30, 2022, or the |the contract. |contract is renewed or extended (e.g., |The contractor must pay all covered workers | an option is exercised) on or after |at least \$17.20 per hour (or the applicable | |January 30, 2022: |wage rate listed on this wage determination, | if it is higher) for all hours spent | performing on the contract in 2024.

The applicable Executive Order minimum wage rate will be adjusted annually. Additional information on contractor requirements and worker protections under the Executive Orders is available at www.dol.gov/whd/govcontracts.

States: Guam, Northern Marianas, Wake Island Area: Guam Statewide Northern Marianas Statewide Wake Island Statewide

****Fringe Benefits Required Follow the Occupational Listing****

OCCUPATION CODE – TITLE	FOOTNOTE	RATE
01000 - Administrative Support And Clerical Occupations		
01011 - Accounting Clerk I		14.27***
01012 - Accounting Clerk II		16.02***
01013 - Accounting Clerk III		17.93
01020 - Administrative Assistant		21.43
01035 - Court Reporter		17.40
01041 - Customer Service Representative I		12.75***
01042 - Customer Service Representative II		14.23***
01043 - Customer Service Representative III		15.62***
01051 - Data Entry Operator I		12.16***
01052 - Data Entry Operator II		13.27***
01060 - Dispatcher, Motor Vehicle		17.39
01070 - Document Preparation Clerk		13.85***
01090 - Duplicating Machine Operator		13.85***
01111 - General Clerk I		11.33***
01112 - General Clerk II		12.36***
01113 - General Clerk III		13.88***
01120 - Housing Referral Assistant		19.39
01141 - Messenger Courier		11.37***
01191 - Order Clerk I		12.57***
01192 - Order Clerk II		13.71***
01261 - Personnel Assistant (Employment) I		15.95***
01262 - Personnel Assistant (Employment) II		17.85
01263 - Personnel Assistant (Employment) III		19.89
01270 - Production Control Clerk		22.97
01290 - Rental Clerk		11.10***
01300 - Scheduler, Maintenance		15.55***
01311 - Secretary I		15.55***
01312 - Secretary II		17.40
01313 - Secretary III		19.39
01320 - Service Order Dispatcher		15.40***
01410 - Supply Technician		21.43
01420 - Survey Worker		16.96***
01460 - Switchboard Operator/Receptionist		10.78***
01531 - Travel Clerk I		13.01***
01532 - Travel Clerk II		14.12***
01533 - Travel Clerk III		15.09***
01611 - Word Processor I		14.53***
01612 - Word Processor II		16.31***
01613 - Word Processor III		18.26
05000 - Automotive Service Occupations		
05005 - Automobile Body Repairer, Fiberglass		17.20
05010 - Automobile Electrician		16.16***
05040 - Automotive Glass Installer		15.11***
05070 - Automotive Worker		15.11***
05110 - Mobile Equipment Servicer		12.96***
05130 - Motor Equipment Metal Mechanic		17.20
05160 - Motor Equipment Metal Worker		15.11***
05190 - Motor Vehicle Mechanic		17.20

05220 - Motor Vehicle Mechanic Helper	11.87***
05250 - Motor Vehicle Upholstery Worker	14.06***
05280 - Motor Vehicle Wrecker	15.11***
05310 - Painter, Automotive	16.16***
05340 - Radiator Repair Specialist	15.11***
05370 - Tire Repairer	12.67***
05400 - Transmission Repair Specialist	17.20
07000 - Food Preparation And Service Occupations	
07010 - Baker	11.10***
07041 - Cook I	14.44***
07042 - Cook II	16.84***
07070 - Dishwasher	9.69***
07130 - Food Service Worker	10.11***
07210 - Meat Cutter	13.34***
07260 - Waiter/Waitress	9.73***
09000 - Furniture Maintenance And Repair Occupations	
09010 - Electrostatic Spray Painter	18.75
09040 - Furniture Handler	11.37***
09080 - Furniture Refinisher	18.75
09090 - Furniture Refinisher Helper	13.77***
09110 - Furniture Repairer, Minor	16.32***
09130 - Upholsterer	18.75
11000 - General Services And Support Occupations	
11030 - Cleaner, Vehicles	9.69***
11060 - Elevator Operator	9.69***
11090 - Gardener	14.28***
11122 - Housekeeping Aide	10.13***
11150 - Janitor	10.13***
11210 - Laborer, Grounds Maintenance	10.79***
11240 - Maid or Houseman	9.67***
11260 - Pruner	9.66***
11270 - Tractor Operator	13.07***
11330 - Trail Maintenance Worker	10.79***
11360 - Window Cleaner	11.32***
12000 - Health Occupations	
12010 - Ambulance Driver	18.96
12011 - Breath Alcohol Technician	18.96
12012 - Certified Occupational Therapist Assistant	26.02
12015 - Certified Physical Therapist Assistant	26.02
12020 - Dental Assistant	18.79
12025 - Dental Hygienist	39.73
12030 - EKG Technician	28.73
12035 - Electroneurodiagnostic Technologist	28.73
12040 - Emergency Medical Technician	18.96
12071 - Licensed Practical Nurse I	16.95***
12072 - Licensed Practical Nurse II	18.96
12073 - Licensed Practical Nurse III	21.14
12100 - Medical Assistant	13.42***
12130 - Medical Laboratory Technician	18.82
12160 - Medical Record Clerk	14.97***
12190 - Medical Record Technician	17.77
12195 - Medical Transcriptionist	16.95***
12210 - Nuclear Medicine Technologist	41.68
12221 - Nursing Assistant I	12.43***
12222 - Nursing Assistant II	13.97***
12223 - Nursing Assistant III	15.24***
12224 - Nursing Assistant IV	17.12***
12235 - Optical Dispenser	18.96
12236 - Optical Technician	16.95***
12250 - Pharmacy Technician	15.49***
12280 - Phlebotomist	16.95***
12305 - Radiologic Technologist	28.73
12311 - Registered Nurse I	23.50
12312 - Registered Nurse II	28.73
12313 - Registered Nurse II, Specialist	28.73
12314 - Registered Nurse III	34.76
12315 - Registered Nurse III, Anesthetist	34.76
12316 - Registered Nurse IV	41.68
12317 - Scheduler (Drug and Alcohol Testing)	23.50
12320 - Substance Abuse Treatment Counselor	23.50

13000 - Information And Arts Occupations		
13011 - Exhibits Specialist I		21.42
13012 - Exhibits Specialist II		26.53
13013 - Exhibits Specialist III		32.45
13041 - Illustrator I		21.42
13042 - Illustrator II		26.53
13043 - Illustrator III		32.45
13047 - Librarian		29.38
13050 - Library Aide/Clerk		17.05***
13054 - Library Information Technology Systems Administrator		26.53
13058 - Library Technician		18.11
13061 - Media Specialist I		19.15
13062 - Media Specialist II		21.42
13063 - Media Specialist III		23.87
13071 - Photographer I		19.15
13072 - Photographer II		21.42
13073 - Photographer III		26.53
13074 - Photographer IV		32.45
13075 - Photographer V		39.27
13090 - Technical Order Library Clerk		21.42
13110 - Video Teleconference Technician		19.15
14000 - Information Technology Occupations		
14041 - Computer Operator I		15.71***
14042 - Computer Operator II		17.22
14043 - Computer Operator III		19.19
14044 - Computer Operator IV		21.33
14045 - Computer Operator V		23.62
14071 - Computer Programmer I	(see 1)	15.73***
14072 - Computer Programmer II	(see 1)	19.50
14073 - Computer Programmer III	(see 1)	23.84
14074 - Computer Programmer IV	(see 1)	
14101 - Computer Systems Analyst I	(see 1)	24.23
14102 - Computer Systems Analyst II	(see 1)	
14103 - Computer Systems Analyst III	(see 1)	
14150 - Peripheral Equipment Operator		15.71***
14160 - Personal Computer Support Technician		21.33
14170 - System Support Specialist		21.24
15000 - Instructional Occupations		
15010 - Aircrew Training Devices Instructor (Non-Rated)		24.23
15020 - Aircrew Training Devices Instructor (Rated)		29.32
15030 - Air Crew Training Devices Instructor (Pilot)		34.91
15050 - Computer Based Training Specialist / Instructor		24.23
15060 - Educational Technologist		29.40
15070 - Flight Instructor (Pilot)		34.91
15080 - Graphic Artist		20.47
15085 - Maintenance Test Pilot, Fixed, Jet/Prop		34.91
15086 - Maintenance Test Pilot, Rotary Wing		34.91
15088 - Non-Maintenance Test/Co-Pilot		34.91
15090 - Technical Instructor		17.67
15095 - Technical Instructor/Course Developer		23.78
15110 - Test Proctor		15.70***
15120 - Tutor		15.70***
16000 - Laundry, Dry-Cleaning, Pressing And Related Occupations		
16010 - Assembler		10.83***
16030 - Counter Attendant		10.83***
16040 - Dry Cleaner		12.36***
16070 - Finisher, Flatwork, Machine		10.83***
16090 - Presser, Hand		10.83***
16110 - Presser, Machine, Drycleaning		10.83***
16130 - Presser, Machine, Shirts		10.83***
16160 - Presser, Machine, Wearing Apparel, Laundry		10.83***
16190 - Sewing Machine Operator		12.88***
16220 - Tailor		13.40***
16250 - Washer, Machine		11.34***
19000 - Machine Tool Operation And Repair Occupations		
19010 - Machine-Tool Operator (Tool Room)		19.46
19040 - Tool And Die Maker		24.46
21000 - Materials Handling And Packing Occupations		
21020 - Forklift Operator		15.36***

21030 - Material Coordinator	22.97	
21040 - Material Expediter	22.97	
21050 - Material Handling Laborer	12.57***	
21071 - Order Filler	10.62***	
21080 - Production Line Worker (Food Processing)	15.36***	
21110 - Shipping Packer	17.12***	
21130 - Shipping/Receiving Clerk	17.12***	
21140 - Store Worker I	15.83***	
21150 - Stock Clerk	22.26	
21210 - Tools And Parts Attendant	15.36***	
21410 - Warehouse Specialist	15.36***	
23000 - Mechanics And Maintenance And Repair Occupations		
23010 - Aerospace Structural Welder	25.04	
23019 - Aircraft Logs and Records Technician	19.47	
23021 - Aircraft Mechanic I	23.84	
23022 - Aircraft Mechanic II	25.04	
23023 - Aircraft Mechanic III	26.30	
23040 - Aircraft Mechanic Helper	16.58***	
23050 - Aircraft, Painter	22.39	
23060 - Aircraft Servicer	19.47	
23070 - Aircraft Survival Flight Equipment Technician	22.39	
23080 - Aircraft Worker	21.03	
23091 - Aircrew Life Support Equipment (ALSE) Mechanic I	21.03	
23092 - Aircrew Life Support Equipment (ALSE) Mechanic II	23.84	
23110 - Appliance Mechanic	19.46	
23120 - Bicycle Repairer	15.61***	
23125 - Cable Splicer	22.47	
23130 - Carpenter, Maintenance	17.58	
23140 - Carpet Layer	18.20	
23160 - Electrician, Maintenance	19.37	
23181 - Electronics Technician Maintenance I	18.20	
23182 - Electronics Technician Maintenance II	19.46	
23183 - Electronics Technician Maintenance III	20.72	
23260 - Fabric Worker	16.94***	
23290 - Fire Alarm System Mechanic	16.77***	
23310 - Fire Extinguisher Repairer	15.61***	
23311 - Fuel Distribution System Mechanic	20.72	
23312 - Fuel Distribution System Operator	15.61***	
23370 - General Maintenance Worker	13.24***	
23380 - Ground Support Equipment Mechanic	23.84	
23381 - Ground Support Equipment Servicer	19.47	
23382 - Ground Support Equipment Worker	21.03	
23391 - Gunsmith I	15.61***	
23392 - Gunsmith II	18.20	
23393 - Gunsmith III	20.72	
23410 - Heating, Ventilation And Air-Conditioning Mechanic	19.27	
23411 - Heating, Ventilation And Air Contidioning Mechanic (Research Facility)	20.50	
23430 - Heavy Equipment Mechanic	19.50	
23440 - Heavy Equipment Operator	18.10	
23460 - Instrument Mechanic	20.72	
23465 - Laboratory/Shelter Mechanic	19.46	
23470 - Laborer	12.57***	
23510 - Locksmith	19.46	
23530 - Machinery Maintenance Mechanic	23.13	
23550 - Machinist, Maintenance	20.72	
23580 - Maintenance Trades Helper	11.77***	
23591 - Metrology Technician I	20.72	
23592 - Metrology Technician II	22.03	
23593 - Metrology Technician III	23.33	
23640 - Millwright	20.72	
23710 - Office Appliance Repairer	19.46	
23760 - Painter, Maintenance	17.04***	
23790 - Pipefitter, Maintenance	19.96	
23810 - Plumber, Maintenance	18.75	
23820 - Pneudraulic Systems Mechanic	20.72	
23850 - Rigger	20.72	

23870 - Scale Mechanic	18.20
23890 - Sheet-Metal Worker, Maintenance	19.55
23910 - Small Engine Mechanic	18.20
23931 - Telecommunications Mechanic I	19.96
23932 - Telecommunications Mechanic II	21.24
23950 - Telephone Lineman	20.62
23960 - Welder, Combination, Maintenance	19.96
23965 - Well Driller	21.13
23970 - Woodcraft Worker	20.71
23980 - Woodworker	15.61***
24000 - Personal Needs Occupations	
24550 - Case Manager	15.01***
24570 - Child Care Attendant	10.09***
24580 - Child Care Center Clerk	13.25***
24610 - Chore Aide	14.06***
24620 - Family Readiness And Support Services Coordinator	15.01***
24630 - Homemaker	16.12***
25000 - Plant And System Operations Occupations	
25010 - Boiler Tender	22.79
25040 - Sewage Plant Operator	22.89
25070 - Stationary Engineer	22.79
25190 - Ventilation Equipment Tender	15.72***
25210 - Water Treatment Plant Operator	22.89
27000 - Protective Service Occupations	
27004 - Alarm Monitor	10.90***
27007 - Baggage Inspector	9.63***
27008 - Corrections Officer	14.59***
27010 - Court Security Officer	14.59***
27030 - Detection Dog Handler	10.90***
27040 - Detention Officer	14.59***
27070 - Firefighter	14.59***
27101 - Guard I	9.63***
27102 - Guard II	10.90***
27131 - Police Officer I	14.59***
27132 - Police Officer II	16.21***
28000 - Recreation Occupations	
28041 - Carnival Equipment Operator	13.24***
28042 - Carnival Equipment Repairer	14.46***
28043 - Carnival Worker	9.78***
28210 - Gate Attendant/Gate Tender	13.18***
28310 - Lifeguard	11.01***
28350 - Park Attendant (Aide)	14.74***
28510 - Recreation Aide/Health Facility Attendant	11.84***
28515 - Recreation Specialist	18.26
28630 - Sports Official	11.74***
28690 - Swimming Pool Operator	17.71
29000 - Stevedoring/Longshoremen Occupational Services	
29010 - Blocker And Bracer	26.02
29020 - Hatch Tender	26.02
29030 - Line Handler	26.02
29041 - Stevedore I	24.21
29042 - Stevedore II	27.82
30000 - Technical Occupations	
30010 - Air Traffic Control Specialist, Center (HFO) (see 2)	43.06
30011 - Air Traffic Control Specialist, Station (HFO) (see 2)	29.69
30012 - Air Traffic Control Specialist, Terminal (HFO) (see 2)	32.70
30021 - Archeological Technician I	18.17
30022 - Archeological Technician II	20.33
30023 - Archeological Technician III	25.19
30030 - Cartographic Technician	25.19
30040 - Civil Engineering Technician	25.19
30051 - Cryogenic Technician I	27.89
30052 - Cryogenic Technician II	30.80
30061 - Drafter/CAD Operator I	18.17
30062 - Drafter/CAD Operator II	20.33
30063 - Drafter/CAD Operator III	22.66
30064 - Drafter/CAD Operator IV	27.89
30081 - Engineering Technician I	16.19***
30082 - Engineering Technician II	18.17

30083 - Engineering Technician III	20.33
30084 - Engineering Technician IV	25.19
30085 - Engineering Technician V	30.80
30086 - Engineering Technician VI	37.27
30090 - Environmental Technician	25.19
30095 - Evidence Control Specialist	25.19
30210 - Laboratory Technician	22.66
30221 - Latent Fingerprint Technician I	27.89
30222 - Latent Fingerprint Technician II	30.80
30240 - Mathematical Technician	25.19
30361 - Paralegal/Legal Assistant I	19.54
30362 - Paralegal/Legal Assistant II	24.21
30363 - Paralegal/Legal Assistant III	29.61
30364 - Paralegal/Legal Assistant IV	35.83
30375 - Petroleum Supply Specialist	30.80
30390 - Photo-Optics Technician	24.92
30395 - Radiation Control Technician	30.80
30461 - Technical Writer I	25.19
30462 - Technical Writer II	30.80
30463 - Technical Writer III	37.27
30491 - Unexploded Ordnance (UXO) Technician I	27.37
30492 - Unexploded Ordnance (UXO) Technician II	33.11
30493 - Unexploded Ordnance (UXO) Technician III	39.69
30494 - Unexploded (UXO) Safety Escort	27.37
30495 - Unexploded (UXO) Sweep Personnel	27.37
30501 - Weather Forecaster I	27.89
30502 - Weather Forecaster II	33.93
30620 - Weather Observer, Combined Upper Air Or (see 2)	22.66
Surface Programs	
30621 - Weather Observer, Senior (see 2)	25.19
31000 - Transportation/Mobile Equipment Operation Occupations	
31010 - Airplane Pilot	33.11
31020 - Bus Aide	8.97***
31030 - Bus Driver	11.73***
31043 - Driver Courier	10.26***
31260 - Parking and Lot Attendant	9.91***
31290 - Shuttle Bus Driver	11.65***
31310 - Taxi Driver	11.41***
31361 - Truckdriver, Light	11.21***
31362 - Truckdriver, Medium	12.16***
31363 - Truckdriver, Heavy	16.11***
31364 - Truckdriver, Tractor-Trailer	16.11***
99000 - Miscellaneous Occupations	
99020 - Cabin Safety Specialist	16.14***
99030 - Cashier	10.01***
99050 - Desk Clerk	9.71***
99095 - Embalmer	27.37
99130 - Flight Follower	27.37
99251 - Laboratory Animal Caretaker I	24.31
99252 - Laboratory Animal Caretaker II	26.56
99260 - Marketing Analyst	21.54
99310 - Mortician	27.37
99410 - Pest Controller	16.07***
99510 - Photofinishing Worker	14.38***
99710 - Recycling Laborer	17.32
99711 - Recycling Specialist	23.38
99730 - Refuse Collector	16.40***
99810 - Sales Clerk	10.63***
99820 - School Crossing Guard	17.96
99830 - Survey Party Chief	23.99
99831 - Surveying Aide	13.65***
99832 - Surveying Technician	17.73
99840 - Vending Machine Attendant	24.31
99841 - Vending Machine Repairer	30.96
99842 - Vending Machine Repairer Helper	24.31

***Workers in this classification may be entitled to a higher minimum wage under Executive Order 14026 (\$17.20 per hour). Please see the Note at the top of the wage determination for more information. Please also note that the minimum wage requirements of Executive Order 14026 are not currently being enforced as to contracts or contract-like instruments entered into with the federal government in connection with seasonal recreational services or seasonal recreational equipment rental for the general public on federal lands. The minimum wage requirements of Executive Order 14026 also are not currently being enforced as to any contract or subcontract to which the states of Texas, Louisiana, or Mississippi, including their agencies, are a party.

ALL OCCUPATIONS LISTED ABOVE RECEIVE THE FOLLOWING BENEFITS:

HEALTH & WELFARE: \$4.98 per hour, up to 40 hours per week, or \$199.20 per week or \$863.20 per month

HEALTH & WELFARE EO 13706: \$4.57 per hour, up to 40 hours per week, or \$182.80 per week, or \$792.13 per month*

*This rate is to be used only when compensating employees for performance on an SCA-covered contract also covered by EO 13706, Establishing Paid Sick Leave for Federal Contractors. A contractor may not receive credit toward its SCA obligations for any paid sick leave provided pursuant to EO 13706.

VACATION: 2 weeks paid vacation after 1 year of service with a contractor or successor; and 4 weeks after 3 years. Length of service includes the whole span of continuous service with the present contractor or successor, wherever employed, and with the predecessor contractors in the performance of similar work at the same Federal facility. (Reg. 29 CFR 4.173)

HOLIDAYS: A minimum of eleven paid holidays per year: New Year's Day, Martin Luther King Jr.'s Birthday, Washington's Birthday, Memorial Day, Juneteenth National Independence Day, Independence Day, Labor Day, Columbus Day, Veterans' Day, Thanksgiving Day, and Christmas Day. (A contractor may substitute for any of the named holidays another day off with pay in accordance with a plan communicated to the employees involved.) (See 29 CFR 4.174)

THE OCCUPATIONS WHICH HAVE NUMBERED FOOTNOTES IN PARENTHESES RECEIVE THE FOLLOWING:

1) COMPUTER EMPLOYEES: This wage determination does not apply to any individual employed in a bona fide executive, administrative, or professional capacity, as defined in 29 C.F.R. Part 541. (See 41 C.F.R. 6701(3)). Because most Computer Systems Analysts and Computer Programmers who are paid at least \$27.63 per hour (or at least \$684 per week if paid on a salary or fee basis) likely qualify as exempt computer professionals under 29 U.S.C. 213(a)(1) and 29 U.S.C. 213(a)(17), this wage determination may not include wage rates for all occupations within those job families. In such instances, a conformance will be necessary if there are nonexempt employees in these job families working on the contract.

Job titles vary widely and change quickly in the computer industry, and are not determinative of whether an employee is an exempt computer professional. To be exempt, computer employees who satisfy the compensation requirements must also have a primary duty that consists of:

(1) The application of systems analysis techniques and procedures, including consulting with users, to determine hardware, software or system functional specifications;

(2) The design, development, documentation, analysis, creation, testing or modification of computer systems or programs, including prototypes, based on and related to user or system design specifications;

(3) The design, documentation, testing, creation or modification of computer programs related to machine operating systems; or

(4) A combination of the aforementioned duties, the performance of which requires the same level of skills. (29 C.F.R. 541.400).

Any computer employee who meets the applicable compensation requirements and the above duties test qualifies as an exempt computer professional under both section 13(a)(1) and section 13(a)(17) of the Fair Labor Standards Act. (Field Assistance Bulletin No. 2006-3 (Dec. 14, 2006)). Accordingly, this wage determination will not apply to any exempt computer employee regardless of which of these two exemptions is utilized.

2) AIR TRAFFIC CONTROLLERS AND WEATHER OBSERVERS - NIGHT PAY & SUNDAY PAY: If you work at night as part of a regular tour of duty, you will earn a night differential and receive an additional 10% of basic pay for any hours worked between 6pm and 6am. If you are a full-time employed (40 hours a week) and Sunday is part of your regularly scheduled workweek, you are paid at your rate of basic pay plus a Sunday premium of 25% of your basic rate for each hour of Sunday work which is not overtime (i.e. occasional work on Sunday outside the normal tour of duty is considered overtime work).

**** HAZARDOUS PAY DIFFERENTIAL ****

An 8 percent differential is applicable to employees employed in a position that represents a high degree of hazard when working with or in close proximity to ordnance, explosives, and incendiary materials. This includes work such as screening, blending, dying, mixing, and pressing of sensitive ordnance, explosives, and pyrotechnic compositions such as lead azide, black powder and photoflash powder. All dry-house activities involving propellants or explosives. Demilitarization, modification, renovation, demolition, and maintenance operations on sensitive ordnance, explosives and incendiary materials. All operations involving re-grading and cleaning of artillery ranges.

A 4 percent differential is applicable to employees employed in a position that represents a low degree of hazard when working with, or in close proximity to ordnance, (or employees possibly adjacent to) explosives and incendiary materials which involves potential injury such as laceration of hands, face, or arms of the employee engaged in the operation, irritation of the skin, minor burns and the like; minimal damage to immediate or adjacent work area or equipment being used. All operations involving, unloading, storage, and hauling of ordnance, explosive, and incendiary ordnance material other than small arms ammunition. These differentials are only applicable to work that has been specifically designated by the agency for ordnance, explosives, and incendiary material differential pay.

**** UNIFORM ALLOWANCE ****

If employees are required to wear uniforms in the performance of this contract (Either by the terms of the Government contract, by the employer, by the state or local law, etc.), the cost of furnishing such uniforms and maintaining (by laundering or dry cleaning) such uniforms is an expense that may not be borne by an employee where such cost reduces the hourly rate below that required by the wage determination. The Department of Labor will accept payment in accordance with the following standards as compliance:

The contractor or subcontractor is required to furnish all employees with an adequate number of uniforms without cost or to reimburse employees for the actual cost of the uniforms. In addition, where uniform cleaning and maintenance is made the responsibility of the employee, all contractors and subcontractors subject to this wage determination shall (in the absence of a bona fide collective bargaining agreement providing for a different amount, or the furnishing of contrary affirmative proof as to the actual cost), reimburse all employees for such cleaning and maintenance at a rate of \$3.35 per week (or \$.67 cents per day). However, in those instances where the uniforms furnished are made of "wash and wear" materials, may be routinely washed and dried with other personal garments, and do not require any special treatment such as dry cleaning, daily washing, or commercial laundering in order to meet the cleanliness or appearance standards

set by the terms of the Government contract, by the contractor, by law, or by the nature of the work, there is no requirement that employees be reimbursed for uniform maintenance costs.

**** SERVICE CONTRACT ACT DIRECTORY OF OCCUPATIONS ****

The duties of employees under job titles listed are those described in the ""Service Contract Act Directory of Occupations"", Fifth Edition (Revision 1), dated September 2015, unless otherwise indicated.

**** REQUEST FOR AUTHORIZATION OF ADDITIONAL CLASSIFICATION AND WAGE RATE, Standard Form 1444 (SF-1444) ****

Conformance Process:

The contracting officer shall require that any class of service employee which is not listed herein and which is to be employed under the contract (i.e., the work to be performed is not performed by any classification listed in the wage determination), be classified by the contractor so as to provide a reasonable relationship (i.e., appropriate level of skill comparison) between such unlisted classifications and the classifications listed in the wage determination (See 29 CFR 4.6(b)(2)(i)). Such conforming procedures shall be initiated by the contractor prior to the performance of contract work by such unlisted class(es) of employees (See 29 CFR 4.6(b)(2)(ii)). The Wage and Hour Division shall make a final determination of conformed classification, wage rate, and/or fringe benefits which shall be paid to all employees performing in the classification from the first day of work on which contract work is performed by them in the classification. Failure to pay such unlisted employees the compensation agreed upon by the interested parties and/or fully determined by the Wage and Hour Division retroactive to the date such class of employees commenced contract work shall be a violation of the Act and this contract. (See 29 CFR 4.6(b)(2)(v)). When multiple wage determinations are included in a contract, a separate SF-1444 should be prepared for each wage determination to which a class(es) is to be confirmed.

The process for preparing a conformance request is as follows:

- 1) When preparing the bid, the contractor identifies the need for a conformed occupation(s) and computes a proposed rate(s).
- 2) After contract award, the contractor prepares a written report listing in order the proposed classification title(s), a Federal Grade Equivalency (FGE) for each proposed classification(s), job description(s), and rationale for proposed wage rate(s), including information regarding the agreement or disagreement of the authorized representative of the employees involved, or where there is no authorized representative, the employees themselves. This report should be submitted to the contracting officer no later than 30 days after such unlisted class(es) of employees performs any contract work.
- 3) The contracting officer reviews the proposed action and promptly submits a report of the action, together with the agency's recommendations and pertinent information including the position of the contractor and the employees, to the U.S. Department of Labor, Wage and Hour Division, for review (See 29 CFR 4.6(b)(2)(ii)).
- 4) Within 30 days of receipt, the Wage and Hour Division approves, modifies, or disapproves the action via transmittal to the agency contracting officer, or notifies the contracting officer that additional time will be required to process the request.
- 5) The contracting officer transmits the Wage and Hour Division's decision to the contractor.
- 6) Each affected employee shall be furnished by the contractor with a written copy of such determination or it shall be posted as a part of the wage determination (See 29 CFR 4.6(b)(2)(iii)).

Information required by the Regulations must be submitted on SF-1444 or bond paper.

When preparing a conformance request, the ""Service Contract Act Directory of Occupations"" should be used to compare job definitions to ensure that duties requested are not performed by a classification already listed in the wage determination. Remember, it is not the job title, but the required tasks that determine whether a class is included in an established wage determination. Conformances may not be used to artificially split, combine, or subdivide classifications listed in the wage determination (See 29 CFR 4.152(c)(1))."

SPECIAL PROVISIONS

**RESTRICTION AGAINST SEX OFFENDERS EMPLOYED BY SERVICE PROVIDERS TO
GOVERNMENT OF GUAM FROM WORKING ON GOVERNMENT PROPERTY**

If a contract for services is awarded to the bidder or offeror, then the service provider must warranty that no person in its employment who has been convicted of a sex offense under the provisions of Chapter 25: Title 9 of Guam Code Annotated, or of an offense defined in Article 2, Chapter 28 of Title 9 of the Guam Code Annotated, or who has been convicted in any other jurisdiction of an offense with the same elements as heretofore defined, or who is listed in the Sex Offender Registry, shall provide services on behalf of the service provider while on Government of Guam property, with the exception of public highways. If any employee of a service provider is providing services on Government property and is convicted subsequent to an award of a contract, then the service provider warrants that it will notify the Government of the conviction within twenty-four (24) hours of the conviction, and will immediately remove such convicted person from providing services on Government property. If the service provider is found to be in violation of any of the provisions of this paragraph, then the Government will give notice to the service provider to take corrective action. The service provider shall take corrective action within twenty-four (24) hours of notice from the Government, and the service provider shall notify the Government when action has been taken. If the service providers fail to take corrective steps within twenty-four (24) hours of notice from the Government, then the Government in its sole discretion may suspend temporarily and contract for services until corrective action has been taken.

_____ Signature of Bidder/Offeror Proposer, if an individual; Partner, if a partnership; Officer, if a corporation.	_____ Date
---	---------------

Subscribed and sworn before me this _____ day of _____, 20__.

Notary Public

*Approved by OMB
0348-0046*

Section XIII. CONFLICT OF INTEREST (COI) DISCLOSURE FORM

Government of Guam *PORT AUTHORITY OF GUAM* IFB No. PAG-CIP-024-003

Offerors under Contract or proposing to enter into a Contract with *PORT AUTHORITY OF GUAM* must comply with the "Conflict of Interest Guidelines" attached to this solicitation. The definitions of terms used in this COI Disclosure Form shall be those provided in the Conflict-of-Interest Guidelines (note that "Public Employee" includes all *PORT AUTHORITY OF GUAM* employees).

THIS COI DISCLOSURE FORM IS SUBMITTED IN RESPONSE TO:

PORT AUTHORITY OF GUAM RFP# _____ [or] IFB# _____ (check only one)
 Contract # _____ (if applicable) Changes to COI Disclosure Form previously submitted for RFP # _____, IFB # _____, or Contract # _____ (if applicable)

This COI disclosure form must be signed in ink by an authorized representative of offeror to certify that it is correct. An offeror's certification that its disclosure form is correct includes the disclosure by its associates and subcontractors.

My signature certifies that as disclosed on or attached to the present form:

- (a) the Offeror's disclosures are complete, accurate, and not misleading.
- (b) the Offeror has provided the COI Guidelines to all Associates and Subcontractors (if any) and this form includes or has attached any required COI disclosures from those sources.

I hereby certify that I am authorized to sign this COI Disclosure Form as an Authorized Representative for the Offeror identified below:

Complete Legal Name of Offeror: _____
Address: _____ **Telephone:** _____
_____ **Fax Number:** _____
Signature: _____ **Date:** _____

Please answer all questions "Yes", "No" or "N/A" (if uncertain answer "Yes.") If the answer to any of the questions is "Yes," then use the applicable "Comments" fields to:

- (a) furnish all relevant facts that are necessary to make the response complete, accurate, and not misleading; and
- (b) identify any actions that must be taken to avoid, neutralize, or mitigate such conflict of interest (e.g. communications barriers, restraint or restriction upon future contracting activities, or other precaution)

Please add additional sheets as necessary to respond to the "Comments" field.

- 1. a) Is any Associate of the Offeror a former employee of *PORT AUTHORITY OF GUAM* within the last year?
No Yes
b) Is any Associate of the Offeror a Relative, Immediate Family Member, or Member of the Household of a current *PORT AUTHORITY OF GUAM* employee that had or will have any involvement with this Procurement or Contract Authorization? No Yes
If the answer to either of the above questions is "Yes", complete the attached "Relatives and Former *PORT AUTHORITY OF GUAM* Employees - Roles and Signatures" table (Part A and/or Part B, as applicable).

- 2. Does the Offeror or any Associate of the Offeror have an Actual, Apparent or Potential Conflict of Interest ("Individual" or "Organizational") with regard to any known member of an *PORT AUTHORITY OF GUAM* Procurement evaluation or selection team? No Yes **Comments:** _____

3. Did the Offeror or any Associate of the Offeror conduct prior work on the Project described in the Procurement, or participate in preparing any part of the Procurement or any documents or reports related to the Procurement or to which the Procurement refers? **No** **Yes** **Comments:** _____
4. Does the Offeror or any Associate of the Offeror have any past, present or currently planned personal or financial interests which are an Actual, Apparent or Potential Conflict of Interest (“Individual” or “Organizational”), with respect to the Procurement or award of this Contract or performing the work for *PORT AUTHORITY OF GUAM* or acquisition of any real property for the Project? **No** **Yes** **Comments:** _____
5. Has the Offeror or an Associate of the Offeror offered to a Public Employee, or is the Offeror aware of any Public Employee that has solicited or received, directly or indirectly, any pledge or promise of employment or other benefit based on the understanding that the Public Employee’s vote, official action or judgment would be influenced thereby?
No **Yes** **Comments:** _____
6. Has (or will) the Offeror or an Associate of the Offeror provided a direct beneficial financial interest to any person within two years after the person ceased to hold a position as a Public Employee who was involved in the Procurement or Authorization for the Contract, or is the Offeror aware of any such person or Public Employee who has or will receive a direct beneficial financial interest within the two-year period? **No** **Yes** **Comments:** _____
7. Is the Offeror aware of any current or former Public Employee that has an Actual, Apparent, or Potential Conflict of Interest with respect to the Procurement or award of this Contract or performing the work for *PORT AUTHORITY OF GUAM*? **No** **Yes** **Comments:** _____
8. Does the prospective Contract/WOC include development of an Environmental Assessment (EA) or Environmental Impact Statement (EIS)? **No** **Yes**
- If yes**, in accordance with the disclosure statement requirements of Council on Environmental Quality Regulation, 40 C.F.R 1506.5(c), does the Offeror have any financial or other interest in the outcome of this Project; and/or does the Offeror have any agreement, enforceable promise, or guarantee to provide any future work on this Project?
No **Yes** **Comments:** _____
9. Have Subcontractors or other Associates furnished COI Disclosure Forms, separate from the present form, which included conflicts or potential conflicts of interest? (If yes, attach the disclosures.) **No** **Yes** **N/A**
Comments: _____
10. If the prospective Contract/WOC includes personal services for the purpose of administering, managing, monitoring, inspecting, evaluating compliance with or otherwise overseeing a public contract, is the Offeror or an Associate or an Affiliate of the Offeror a party to the subject public contract?
No **Yes** **N/A** **Comments:** _____
11. Has the Offeror or any Associate of the Offeror entered into personal services contract(s) with *PORT AUTHORITY OF GUAM* for the purpose of advising or assisting in developing specifications, a scope or statement of work, an invitation to bid, a request for proposals, or other solicitation documents and materials related to this procurement?
No **Yes** **Comments:** _____

Relatives and Former *PORT AUTHORITY OF GUAM* Employees - Roles and Signatures

For each employee of the Offeror that was employed by *PORT AUTHORITY OF GUAM* within the last year, state the job the employee performed for *PORT AUTHORITY OF GUAM*, the role the employee now serves for the Offeror and the date the employee left *PORT AUTHORITY OF GUAM*. Use Part B for Offeror Associates with Relatives, Immediate Family Members, or Members of the Household working for *PORT AUTHORITY OF GUAM* that have had or will have involvement with this Procurement or Contract.

PART A: EMPLOYEES THAT LEFT *PORT AUTHORITY OF GUAM* IN THE LAST YEAR.			
Employee Name/Signature	Job Performed for *PORT AUTHORITY OF GUAM*	Current Role with Offeror	Date left *PORT AUTHORITY OF GUAM*
Name: _____ Sign: _____ ▪ Involved with this Procurement on behalf of *PORT AUTHORITY OF GUAM*? No <input type="checkbox"/> Yes <input type="checkbox"/> ▪ Involved with Proposal development for this Procurement? No <input type="checkbox"/> Yes <input type="checkbox"/>			
Name: _____ Sign: _____ ▪ Involved with this Procurement on behalf of *PORT AUTHORITY OF GUAM*? No <input type="checkbox"/> Yes <input type="checkbox"/> ▪ Involved with Proposal development for this Procurement? No <input type="checkbox"/> Yes <input type="checkbox"/>			
Name: _____ Sign: _____ ▪ Involved with this Procurement on behalf of *PORT AUTHORITY OF GUAM*? No <input type="checkbox"/> Yes <input type="checkbox"/> ▪ Involved with Proposal development for this Procurement? No <input type="checkbox"/> Yes <input type="checkbox"/>			
Part B: Identify Associates of the Offeror that are Relatives, Immediate Family Members, or Members of the Household of *PORT AUTHORITY OF GUAM* employees currently working for *PORT AUTHORITY OF GUAM*, if the *PORT AUTHORITY OF GUAM* employee had or will have any involvement with this Procurement or Contract.			
Offeror Associate's Name	Name and Relationship of Relative, Immediate Family Member, or Member of Household Employed at *PORT AUTHORITY OF GUAM*	Role at *PORT AUTHORITY OF GUAM*	*PORT AUTHORITY OF GUAM* employee's Role with this Procurement

(Make copies of this form as needed to list additional employees.)

VOLUME 4
SAMPLE CONSTRUCTION AGREEMENT &
PERFORMANCE AND PAYMENT BOND FORM

**AGREEMENT
BETWEEN
JOSE D. LEON GUERRERO COMMERCIAL PORT
AND
CONTRACTOR**

THIS AGREEMENT (“Agreement”) is entered into by and between the **JOSE D. LEON GUERRERO COMMERCIAL PORT**, also known as the **PORT AUTHORITY OF GUAM**, a public corporation and autonomous instrumentality of the Government of Guam, whose address is 1026 Cabras Highway, Suite 201, Piti, Guam 96915 (the “Port”), and **CONTRACTOR** (“Contractor”), a Guam corporation authorized and licensed to do business in Guam, whose address is XXX E. Harmon Industrial Park Road Units XXX, Tamuning, Guam 969XX, with reference to the following facts:

RECITALS

A. The Port previously issued an Invitation for Bid Seeking Construction Services work for the **WAREHOUSE 1 ROOF VENT REPLACEMENT PROJECT**, under the **Invitation for Bid PAG-CIP-024-003**, a copy of which is attached to this Agreement as **EXHIBIT 1** and incorporated herein by this reference (the “IFB”).

B. Pursuant to the IFB, the Port solicited sealed bids from qualified bidders for the **WAREHOUSE 1 ROOF VENT REPLACEMENT PROJECT**, under the **Invitation for Bid PAG-CIP-024-003**.

C. Contractor responded to the IFB by submitting a bid to provide the services described in the IFB, a copy of which is attached to this Agreement as **EXHIBIT 2** and incorporated herein by this reference (the “Bid”), and was selected by the Port as the lowest and most responsible and responsive qualified bidder.

D. The Port and Contractor have agreed to execute this Agreement in order to memorialize the terms and conditions on which Contractor shall provide the Construction Services to the Port.

NOW, THEREFORE, the parties hereto, intending to be legally bound, do hereby agree as follows:

1. SERVICES TO BE PERFORMED

1.1 Scope of Work. Contractor shall provide the services identified in the IFB and incorporated by reference as if fully set forth therein; and Contractor shall provide status reports on the services performed and required under this Agreement upon request by the Port. Contractor acknowledges and agrees that failure to promptly and satisfactorily perform all the services required under this Agreement constitutes a material breach of this Agreement.

1.2 Contractor Provisions of Resources. Contractor agrees to furnish all qualified personnel, facilities, tools, equipment, materials and transportation to perform the services and work provided for in this Agreement. Contractor represents and warrants that it and its employees possess the professional and technical expertise and knowledge, resources and experience to perform the services described herein in a professional, skillful and diligent manner. The Port may, in its sole discretion, provide staff assistance to Contractor in furtherance of this Agreement. Contractor acknowledges and agrees that its employees, agents and all other personnel engaged to provide the services hereunder shall be informed of all relevant provisions of this Agreement.

1.3 Location of Services. Except as otherwise approved by the Port, the site for services rendered under this Agreement shall be the Port Authority of Guam, Cabras Hwy., Piti, Guam and the Port’s property in the jurisdiction of Piti at the Port Authority of Guam Compound and Administrative Bldg.

1.4 Site Condition Contractor’s Responsibility. Contractor accepts the conditions at the construction site as they eventually may be found to exist and warrants and represents that the services under this Agreement can and shall be performed under such conditions, and that all materials, equipment, labor and other facilities required because of any unforeseen conditions (physical or otherwise) shall be solely at Contractor's own cost and expense, anything in this Agreement to the contrary notwithstanding.

1.5 Firm Fixed Price Contract

This contract offered is a Firm Fixed-Price contract. This price is not subject to adjustment or increase because of variations in the Contractor's actual cost of performing the work and services specified in the IFB and contract documents. Any price adjustments may only be made in accordance with valid, approved Change Orders pursuant to the Change Orders Clause of the contract and the Price Adjustment Clause of the contract.

2. TERMS OF AGREEMENT

2.1 Completion of Services. This Agreement shall be effective on the last signature date set forth on the signature page below, and shall continue until Contractor completes all services required hereunder unless earlier terminated in accordance with the terms of this Agreement. Contractor shall commence the performance of services required hereunder upon its receipt of a Notice to Proceed issued by the Port, and Contractor shall complete all required services under this Agreement within **One Hundred Eighty-Two (182) calendar days from the issuance of a Notice to Proceed by the Port.**

2.2 Liquidated Damages. Contractor acknowledges and agrees that any delays in the completion of the services required hereunder shall subject Contractor to liquidated damages. For each day beyond the expiration of the **One Hundred Eighty-Two (182) calendar day** period after the issuance of the Notice to Proceed, Contractor agrees to pay, not as a penalty but as liquidated damages, **One Thousand Dollars and Zero Cents (\$1,000.00)** per day to the Port. The parties agree that the foregoing amount is a reasonable amount for liquidated damages under the circumstances existing at the time this Agreement is entered into and constitutes a reasonable estimate of damages to the Port for any delays in the completion of services.

3. COMPENSATION

3.1 Compensation. In consideration for the services performed under this Agreement, the Port shall pay to Contractor an aggregate amount equal to **(DOLLAR AMOUNT \$ _____)** in accordance with the terms and conditions set forth in this Agreement (the "Compensation"). The Compensation shall include any applicable Gross Receipts Tax.

3.2 Payment Terms

(a) IFB. The Port shall pay the Compensation to Contractor in accordance with the terms set forth in the IFB, and more specifically, the General Conditions section of the IFB.

(b) Final Payment. Final payment shall be made upon satisfactory performance of all services required to be performed by Contractor under this Agreement. Prior to the final payment due Contractor, and as a condition precedent thereto, Contractor shall execute and deliver to the Port a release in a form approved by the Port of claims against the Port arising under this Agreement. Contractor agrees to expressly waive the provision of section 82602 of Title 18, Guam Code Annotated, which states:

A general release does not extend to claims which the creditor does not know or suspect to exist in his favor at the time of executing the release, which if known by him must have materially affected his settlement with the debtor

3.3 Expenses. Contractor shall be solely responsible for all expenses incurred in the performance of services under this Agreement.

3.4 No Compensation Prior to Approval of Agreement. Contractor hereby waives any and all claims for any services performed by Contractor prior to (i) the full execution of this Agreement by all parties, and (ii) Contractor's receipt of a Notice to Proceed issued by the Port.

3.5 United States Currency. The Compensation payable to Contractor shall be in the currency of the United States.

4. TERMS FOR MULTI-TERM CONTRACTS

Any contract awarded under this IFB is subject to the availability of certified funds. The Procurement Officer will notify the Contractor on a timely basis whether the funds are, or are not, available for the continuation of the contract for each succeeding fiscal period. In the event that funds are not available for any succeeding fiscal period, the contract shall be cancelled; however, this does not affect either Party's right to terminate under the termination clauses of the contract. If the contract is cancelled for insufficient funds, the awarded Contractor shall be reimbursed its unamortized, reasonably incurred, non-recurring costs.

5. TERMINATION OF AGREEMENT

Termination for Default, Nonperformance or Delay, Damages for Delay, Time Extensions.

1. Default. If Contractor refuses or fails to perform any of the provisions of the contract awarded under this solicitation with such diligence as will ensure its completion within the time specified, or any extension thereof, otherwise fails to timely satisfy the contract provisions, or commits any other substantial breach of these terms, PAG may notify Contractor in writing of the delay or non-performance and if not cured in ten days or any longer time specified in writing by PAG, PAG may terminate Contractor's right to proceed with the contract or such part of the contract as to which there has been delay or a failure to properly perform. In the event of termination in whole or in part PAG may procure similar supplies or services in a manner and upon terms deemed appropriate by the PAG. Contractor shall continue performance of the contract to the extent it is not terminated and shall be liable for excess costs incurred in procuring similar goods or services.

2. Contractor's Duties. Notwithstanding termination of the contract and subject to any directions from the PAG, Contractor shall take timely, reasonable, and necessary action to protect and preserve property in the possession of Contractor in which the PAG and the government of Guam has an interest.

3. Compensation. Payment for completed supplies delivered and accepted by PAG shall be at the contract price. Payment for the protection and preservation of property shall be in an amount agreed upon by Contractor and the PAG; if the parties fail to agree, the PAG shall set an amount subject to Contractor's rights under Article 9 (Legal and Contractual Remedies) of the Guam Procurement Regulations. PAG may withhold from amounts due Contractor such sums as the PAG deems to be necessary to protect the PAG against loss because of outstanding liens or claims of former lien holders and to reimburse the PAG for the excess costs incurred in procuring similar goods and services.

4. Excuse for Nonperformance or Delayed Performance. Except with respect to defaults of subcontractors, Contractor shall not be in default by reason of any failure in performance of the contract in accordance with its terms (including any failure by Contractor to make progress in the prosecution of the work hereunder which endangers such performance) if Contractor has notified the PAG within 15 days after the cause of the delay and the failure arises out of causes such as: acts of God; acts of the public enemy; acts of the government of Guam and any other governmental entity in its sovereign or contractual capacity; fires; floods; epidemics; quarantine restrictions; strikes or other labor disputes; freight embargoes; or unusually severe weather. If the failure to perform is caused by the failure of a subcontractor to perform or to make progress, and if such failure arises out of causes similar to those set forth above, Contractor shall not be deemed to be in default, unless the supplies or services to be furnished by the subcontractor were reasonably obtainable from other sources in sufficient time to permit Contractor to meet the contract requirements. Upon request of Contractor, the PAG shall ascertain the facts and extent of such failure, and, if such officer determines that any failure to perform was occasioned by any one or more of the excusable causes, and that, but for the excusable cause, Contractor's progress and performance would have met the terms of the Agreement, the delivery schedule shall be revised accordingly, subject to the rights of the government of Guam under the clause entitled (in fixed-price contracts, "Termination" for

Convenience in cost-reimbursement contracts) "Termination". (As used in this Paragraph of this clause the term "subcontractor" means subcontractor at any tier.)

5. Erroneous Termination for Default. If, after notice of termination of Contractor's right to proceed under the provisions of this clause, it is determined for any reason that Contractor was not in default under the provisions of this clause, or that the delay was excusable under the provisions of Paragraph (4) (Excuse for Nonperformance or Delayed Performance) of this clause, the rights and obligations of the parties shall, be the same as if the notice of termination had been issued pursuant to the clause providing for termination for convenience.

6. Additional Rights and Remedies. The rights and remedies provided in this clause are in addition to any other rights and remedies provided by law or under this solicitation or awarded contract.

B. Termination for Convenience

1. PAG may, when the interest of PAG so require, terminate any awarded contract in whole or in part, for the convenience of PAG or the government of Guam. PAG shall give written notice of the termination to Contractor specifying the part of the contract terminated and when termination becomes effective.

2. Contractor shall incur no further obligations in connection with the terminated work and on the date set in the notice of termination Contractor will stop work to the extent specified. Contractor shall also terminate outstanding orders and subcontracts as they relate to the terminated work. Contractor shall settle the liabilities and claims arising out of the termination of subcontracts and orders connected with the terminated work.

C. Compensation.

1. Contractor shall submit a termination claim specifying the amounts due because of the termination for convenience together with cost or pricing data to the extent required by 2 GAR, Div. 4, § 3118 (Cost or Pricing Data) of the Guam Procurement Regulations bearing on such claim. If Contractor fails to file a termination claim within one year from the effective date of termination, the PAG may pay Contractor, if at all, an amount set in accordance with Subparagraph (c) of this Paragraph.

2. The PAG and Contractor may agree to a settlement provided the Contractor has filed a termination claim supported by cost or pricing data to the extent required by 2 GAR, Div. 4, § 3118 (Cost or Pricing Data) of the Guam Procurement Regulations and that the settlement does not exceed the total contract price plus settlement costs reduced by payments previously made by the PAG, and the contract price of the work not terminated.

3. Absent complete agreement under Subparagraph (2) of this Paragraph, the PAG shall pay Contractor the following amounts, provided payments agreed to under Subparagraph (b) shall not duplicate payments under this Subparagraph:

- (i) contract prices for services accepted under the Agreement;
- (ii) costs incurred in preparing to perform and performing the terminated portion of the work plus a fair and reasonable profit on such portion of the work (such profit shall not include anticipatory profit or consequential damages) that shall be no less than the fees due for the portion of the term calculated up-through the date of termination calculated on a pro-rata basis, less amounts paid or to be paid for accepted services; provided, however, that if it appears that Contractor would have sustained a loss if the entire Agreement would have been completed, no profit shall be allowed or included and the amount of compensation shall be reduced to reflect the anticipated rate of loss;
- (iii) costs of settling and paying claims arising out of the termination of subcontracts or orders pursuant to Paragraph (b) of this clause. These costs must not include costs paid in accordance with Subparagraph (3)(b) of this Paragraph;
- (iv) the reasonable settlement costs of Contractor including accounting, legal, clerical, and other expenses reasonably necessary for the preparation of settlement claims and supporting data with respect to the terminated

portion of the Agreement for the termination and settlement of subcontracts thereunder, together with reasonable storage, transportation, and other costs incurred in connection with the protection or disposition of property allocable to the terminated portion of this Agreement.

The total sum to be paid Contractor under this Subparagraph shall not exceed the total contract price plus the reasonable settlement costs of Contractor reduced by the amount of payments otherwise made and the contract price of work not terminated.

4. Cost claimed, agreed to, or established under Subparagraph (b) and (c) of this Paragraph shall be in accordance with Article 7 (Cost Principles) of the Guam Procurement Regulations.

6. CHANGES

A. **Change Order.** The Procurement Officer, at any time, and without notice to the sureties, in a signed writing designated or indicated to be a change order, may order:

- (1) changes in the services within the scope of the Agreement; and
- (2) changes in the time for performance of the Agreement that do not alter the scope of the Agreement.

All contract change orders must be approved in writing by the Port Authority of Guam on a form approved by Port Authority of Guam to record change orders.

B. **Adjustments of Price or Time for Performance.** The Port Authority of Guam reserves the right to increase or decrease the number of any unit priced quantity as may be deemed reasonable or necessary in order to complete the Services contemplated under this Agreement. If any such change order increases or decreases the Contractor's cost of, or the time required for, performance of any part of the services under this Agreement, whether or not changed by the order, an adjustment shall be made and the Agreement modified in writing accordingly. Any adjustment in contract price made pursuant to this clause shall be determined in accordance with the Standard Price Adjustment Clause of this Agreement. Failure of the parties to agree to an adjustment shall not excuse a Contractor from proceeding with the Agreement as changed, provided that the government of Guam promptly and duly make such provisional adjustments in payments or time for performance as may be reasonable. By proceeding with the services, the Contractor shall not be deemed to have prejudiced any claim for additional compensation, or an extension of time for completion. All changes must be recorded on a contract change order before they can be included in an application for payment/invoice.

C. **Written Certification.** The Contractor shall not perform any change order in excess of \$5,000 unless it bears, or the Contractor has separately received, a written certification, signed by the Procurement Officer/CEO or other responsible official that funds are available therefor; and, if acting in good faith, the Contractor may rely upon the validity of such certification.

D. **Time Period for Claim.** Within 30 days after receipt of a written change order under Paragraph (1) (Change Order) of this clause, unless such period is extended by the Procurement Officer in writing, the Contractor shall file notice of intent to assert a claim for an adjustment. Later notification shall not bar the Contractor's claim unless the government of Guam is prejudiced by the delay in notification.

E. **Claim Barred After Final Payment.** No claim by the Contractor for an adjustment hereunder shall be allowed if notice is not given prior to final payment under this Agreement.

F. **Claims Not Barred.** In the absence of such a change order, nothing in this clause shall restrict the Contractor's right to pursue a claim arising under the Agreement, if pursued in accordance with the clause entitled Claims Based Upon the Port Authority of Guam's Actions or Omissions or for breach of contract.

7. STANDARD PRICE ADJUSTMENT CLAUSE

A. **Price Adjustment Methods.** Any adjustment in contract price pursuant to clauses in this Agreement shall be made in one or more of the following ways:

- 1) by agreement on a fixed price adjustment before commencement of the pertinent performance or as soon thereafter as practicable;
- 2) by unit prices specified in the Proposal, Agreement, or subsequently agreed upon;
- 3) by the costs attributable to the event or situation covered by the clause, plus appropriate profit or fee, all as specified in the Agreement or subsequently agreed upon;
- 4) in such other manner as the parties may mutually agree; or
- 5) in the absence of an agreement between the parties, by a unilateral determination by the Procurement Officer of costs attributable to the event or situation covered by the clause, plus appropriate profit or fee, all as computed by the Procurement Officer in accordance with generally accepted accounting principles and applicable sections under Chapter 7 (Cost Principles) of the Guam Procurement Regulations and subject to the provisions of Article 5, Chapter 5 of 5 GCA (Legal and Contractual Remedies) of the Guam Procurement Law.

B. **Submission of Cost or Pricing Data.** The Contractor shall submit cost or pricing data for any price adjustments subject to the provision of Section 3118 (Cost or Pricing Data) of the Guam Procurement Regulations. The Port Authority of Guam may require the Contractor to provide invoices, paid bills, or any other proof it deems appropriate to determine compliance with this provision.

8. CONTACT PERSON.

Contractor agrees that, during the term of this Agreement, it shall identify a primary contact person who is familiar with the services being performed hereunder and who shall be responsible for responding to the questions and direction of the Port. The contact person must be identified in writing within five (5) days after full execution of this Agreement by all parties. The Port reserves the right to request replacement of the contact person designated by Contractor under this Agreement.

9. CONFIDENTIALITY

9.1 Confidential Information. Contractor hereby warrants that it shall not disclose any documents, materials or information, whether verbal, written, recorded magnetic media or otherwise (collectively, the "Confidential Information"), made available or acquired for the purpose of carrying out this Agreement. Only authorized persons shall use and have access to the Confidential Information, and then only for the period such access is required to perform services under this Agreement. All necessary steps shall be taken by Contractor to safeguard the confidentiality of the Confidential Information in conformance with the terms of this Agreement and any applicable federal and local laws, statutes and regulations.

(a) The obligations under this Section 6 shall survive termination of this Agreement. Upon termination of this Agreement, all Confidential Information shall be returned promptly to the Port and all copies or derivations of the Confidential Information shall be physically and/or electronically destroyed. Contractor shall include a letter attesting to the return of Confidential Information and documenting the destruction of copies and derivations with the returned Confidential Information.

(b) Contractor shall not enter into any agreements or discussions with a third party concerning the Confidential Information without the prior written consent of the Port, and then only if Contractor requires the third party to agree to the terms of this Section 6 and the Confidential Information is provided to such third party only for purposes of enabling Contractor to discharge its responsibilities under this Agreement.

(c) The confidentiality obligations set forth in this Section 6 shall not apply (i) to the extent required by applicable law, (ii) to the extent that any Confidential Information is now or hereafter becomes part of the public domain, but only to the limited extent that such Confidential Information, or any portion thereof, is in the public domain not as a result of any breach or violation of this Agreement, or (iii) to the extent that a party is directed otherwise under the terms of a valid and effective order issued by a court of competent jurisdiction.

9.2 Equitable Relief. Contractor (a) acknowledges that any violation of the provisions of this Section 6 may cause to the Port immediate and irreparable damage for which the Port cannot be adequately compensated by monetary damages, (b) therefore agrees that in the event of any such breach, the Port shall be entitled to such preliminary or other injunctive relief, an order for specific performance, and any other equitable relief as a court may determine to be appropriate, (c) hereby waives any requirement that the Port post, as a condition or other requirement of obtaining any such equitable relief, a bond or other collateral, and (d) further agrees that such equitable relief shall be in addition to any damages or other remedies provided by law and otherwise available to the Port by reason of Contractor's breach.

10. CONFLICTS OF INTERESTS; ETHICS

10.1 Contractor warrants and covenants that it has not violated and will not violate Guam's procurement law or regulations pertaining to ethics in public contracting.

10.2 Notwithstanding any other provision in this Agreement, Contractor acknowledges and agrees that any breach by Contractor of the covenants or warranties in this Section 7 shall be deemed a material breach of this Agreement and shall entitle the Port to immediately terminate this Agreement without liability.

11. PROHIBITION AGAINST GRATUITIES, KICKBACKS AND FAVORS

5GCA Government Operations Chapter 5 Guam Procurement Law § 5630. Gratuities Kickbacks, and Favors

(a) **Gratuities.** It shall be a breach of ethical standards for any person to offer, give or agree to give any employee or former employee, or for any employee or former employee to solicit, demand, accept or agree to accept from another person, a gratuity or an offer of employment in connection with any decision, approval, disapproval, recommendation, preparation of any part of a program requirement or a purchase request, influencing the content of any specification or procurement standard, rendering of advice, investigation, auditing, or in any other advisory capacity in any proceeding or application, request for ruling, determination, claim or controversy, or other particular matter, pertaining to any program requirement or a contract or subcontract; or to any solicitation or proposal therefor.

(b) **Kickbacks.** It shall be a breach of ethical standards for any payment, gratuity or offer of employment to be made by or on behalf of a subcontractor under a contract to the prime contractor or higher tier subcontractor or any person associated therewith, as an inducement for the award of a subcontract or order.

(c) **Contract Clause.** The prohibition against gratuities, kickbacks and favors to Guam prescribed in this Section shall be conspicuously set forth in every contract and solicitation therefor.

(d) **Favors to Guam.** For purposes of this Section, a favor is anything, including raffle tickets, of more than de minimis value and whether intended for the personal enjoyment of the receiver or for the department or organization in which they are employed or for any person, association, club or organization associated therewith or sponsored thereby. It shall be a breach of ethical standards for any person who is or may become a contractor, a subcontractor under a contract to the prime contractor or higher tier contractor, or any person associated therewith, to offer, give or agree to give any employee or agent of Guam or for any employee or agent of Guam to solicit or accept from any such person or entity or agent thereof, a favor or gratuity on behalf of Guam whether or not such favor or gratuity may be considered a reimbursable expense of Guam, during the pendency of any matter related to procurement, including contract performance warranty periods.

12. PROHIBITION AGAINST CONTINGENT FEES

It shall be a breach of ethical standards for a person to be retained, or to retain a person, to solicit or secure a territorial contract upon an agreement or understanding for a commission, percentage, brokerage or contingent fee, except for retention of bona fide employees or bona fide established commercial selling agencies for the purpose of securing business.

13. ETHICAL STANDARD

It shall be a breach of ethical standards for an Offeror to knowingly influence a government employee to breach any of the ethical standards set forth in 5 GCA Chapter 5 Article 11 (Ethics in Public Contracting) of the Guam Procurement Law and in Article 11 of the government of Guam Procurement Regulations.

14. INDEMNIFICATION

14.1 Indemnification. Contractor shall indemnify and hold the Port and each of its officers, agents, Board members and employees, harmless from and against all claims, losses, expenses, injuries, damages, actions, lawsuits, judgments, and all other liabilities, including reasonable attorneys' fees for the defense thereof, arising from or relating to (i) Contractor's breach or failure to perform any of its obligations under this Agreement, (ii) the inaccuracy of any representation or warranty of Contractor under this Agreement, (iii) any violation of or noncompliance with any federal or local law or regulation by Contractor, or (iv) any act or omission of Contractor or its employees, officers, directors, contractors, agents, representatives, successors, or assigns, in the performance or nonperformance of services under this Agreement.

14.2 No Liability. The Port assumes no liability for any accident, loss, claim, judgment, action or injury that may occur with respect to Contractor, Contractor's officers, directors, agents, servants, subcontractors or employees, or to the personal property of any such person or entity, arising out of the performance of services under this Agreement except to the extent caused by the willful misconduct of the Port. No Board member, officer, agent, or employee of the Port shall be personally liable to Contractor under or by reason of this Agreement or any of its provisions.

15. SUSPENSION OF WORK

15.1 Suspension for Convenience. The Port may order Contractor in writing to suspend, delay, or interrupt all or any part of the work for such period of time as the Port may determine to be appropriate for the convenience of the territory.

15.2 Adjustment of Cost. If the performance of all or any part of the work is, for an unreasonable period of time, suspended, delayed, or interrupted by an act of Port in the administration of this Agreement, or by the failure of the Port to act within the time specified in this Agreement (or if no time is specified, within reasonable time), an adjustment shall be made for any increase in the cost of performance of this Agreement necessarily caused by such unreasonable suspension, delay, or interruption and this Agreement modified in writing accordingly. However, no adjustment shall be made under this clause for any suspension, delay, or interruption to the extent:

(a) that performance would have been so suspended, delayed, or interrupted by any other cause, including the fault or negligence of Contractor; or

(b) such adjustment is provided for or excluded under any other provision of this Agreement.

15.3 Time Restriction on Claim. No claim under this Section 11 shall be allowed:

(a) for any costs incurred more than twenty (20) days before Contractor shall have notified the Port in writing of the act or failure to act involved (but this requirement shall not apply as to a claim resulting from a suspension order); and

(b) unless the claim is asserted in writing as soon as practicable after the termination of such suspension, delay, or interruption, but not later than the date of final payment under the contract.

15.4 Adjustments of Price. Any adjustment in the Compensation payable under this Agreement made pursuant to this Section 11 shall be determined in accordance with Section 12, below.

16. DISPUTES

A. The Port Authority of Guam and the Contractor agree to attempt resolution of all controversies which arise under, or are by virtue of, this procurement and any resulting contract through mutual agreement. If the controversy is not resolved by mutual agreement, then the Contractor shall request the government in writing to issue a final decision within sixty days after receipt of the written request. If the government does not issue a written decision within sixty days after written request for a final decision, or within such longer period as may be agreed upon by the parties, then the Contractor may proceed as though the government had issued a decision adverse to the Contractor.

B. The Port Authority of Guam shall immediately furnish a copy of the decision to the Contractor, by certified mail with a return receipt requested, or by any other method that provides evidence of receipt.

C. The Port Authority of Guam's decision shall be final and conclusive, unless fraudulent or unless the Contractor appeals the decision.

D. This subsection applies to appeals of Port's decision on a dispute. For money owed by or to the Port Authority of Guam under this Agreement, the Contractor shall appeal the decision in accordance with the Government Claims Act by initially filing a claim with the Office of the Attorney General no later than eighteen months after the decision is rendered by the Port Authority of Guam or from the date when a decision should have been rendered. For all other claims by or against the Port Authority of Guam arising under this Agreement, the Office of the Public Auditor has jurisdiction over the appeal from the decision of *AGENCY*. Appeals to the Office of the Public Auditor must be made within sixty days of *AGENCY*'s decision or from the date the decision should have been made.

E. The Contractor shall exhaust all administrative remedies before filing an action in the Superior Court of Guam in accordance with applicable laws.

F. The Contractor shall comply with the Port's decision and proceed diligently with performance of the Agreement pending final resolution by the Superior Court of Guam of any controversy arising under, or by virtue of, the Agreement, except where the Contractor claims a material breach of the Agreement by the Port. However, if the Port determines in writing that continuation of services under the Agreement is essential to the public's health or safety, then the Contractor shall proceed diligently with performance of the Agreement notwithstanding any claim of material breach by the Port.

17. CLAIMS BASED ON PORT ACTIONS OR OMISSIONS

17.1 Notice of Claim. If any action or omission on the part of the Port requiring performance changes within the scope of this Agreement constitutes the basis for a claim by Contractor for additional compensation, damages, or an extension of time for completion, Contractor shall continue with performance of this Agreement in compliance with the directions or orders of the Port, but by so doing, Contractor shall not be deemed to have prejudiced any claim for additional compensation, damages, or an extension of time for completion; provided:

(a) Contractor shall have given written notice to the Port:

(i) prior to the commencement of the services involved, if at that time the contractor knows of the occurrence of such action or omission;

(ii) within 30 days after Contractor knows of the occurrence of such action or omission, if Contractor did not have such knowledge prior to the commencement of the services; or

(iii) within such further time as may be allowed by the Port in writing.

The notice shall state that Contractor regards the act or omission as a reason which may entitle Contractor to additional compensation, damages, or an extension of time. The Port, upon receipt of such notice, may rescind such action, remedy such omission, or take such other steps as may be deemed advisable in the discretion of the Port.

(b) The notice required by Section 13.1(a), above, describes as clearly as practicable at the time the reasons why Contractor believes that additional compensation, damages, or an extension of time may be remedies to which Contractor is entitled; and

(c) Contractor maintains and, upon request, makes available to the Port within a reasonable time, detailed records to the extent practicable, of the claimed additional costs or basis for an extension of time in connection with such changes.

17.2 Limitations of Clause. Nothing in this Section 13, however, shall excuse Contractor from compliance with any rules of law precluding any territorial officers and any contractors from acting in collusion or bad faith in issuing or performing change orders which are clearly not within the scope of this Agreement.

17.3 Adjustments of Price. Any adjustment in the Compensation payable under this Agreement made pursuant to this Section 13 shall be determined in accordance with Section 12, above.

18. MODIFICATIONS INCLUDING THOSE DUE TO PUBLIC WELFARE, CHANGE IN LAW OR CHANGE IN MARKETING CONDITIONS. The Port shall have the unilateral power to modify this Agreement at any time subject to the written agreement of Contractor. The Port shall have the power to make changes in this Agreement and to impose new rules and regulations on Contractor under this Agreement relative to the scope and methods of providing services as shall from time-to-time be necessary and desirable for the public welfare or due to a change in law. The Port shall give Contractor notice of any proposed change in this Agreement and an opportunity to be heard concerning those matters. The scope and method of providing services as referenced herein shall also be liberally construed to include, but is not limited to, the manner, procedures, operations and obligations, financial or otherwise, of Contractor. In the event the Port materially alters the obligations of Contractor, or the benefits to the Port, then this Agreement shall be amended consistent therewith. Should these amendments materially alter the obligations of Contractor, then Contractor or the Port shall be entitled to an adjustment in the rates and charges established under this Agreement. Contractor shall be entitled to terminate this Agreement rather than accept modified terms. Nothing contained in this Agreement shall require any party to perform any act or function contrary to law. The Port and Contractor agree to enter into good faith negotiations regarding modifications to this Agreement, which may be required in order to implement changes in the interest of the public welfare or due to changes in law. When such modifications are made to this Agreement, the Port and Contractor shall negotiate in good faith a reasonable and appropriate adjustment for any changes in services or other obligations required of Contractor directly and demonstrably due to any modification in this Agreement under this Section 14.

19. INDEPENDENT CONTRACTOR AND ITS EMPLOYEES

19.1 Status. Contractor acknowledges that in performing services pursuant to this Agreement, Contractor (a) shall be an independent contractor and not an employee of the Port, (b) shall not be entitled to participate in any fringe benefit programs established by the Port for the benefit of its employees, and (c) shall be solely responsible for paying prior to delinquency, and shall indemnify, defend, and hold the Port free and harmless from and against, all income taxes, self-employment taxes, and other taxes (including any interest and penalties with respect thereto) imposed on the fees and compensation paid by the Port to Contractor pursuant to this Agreement.

19.2 Limitation on Authority. Contractor (a) shall not be an agent of the Port and shall have no authority to bind the Port or incur any liabilities in the name of the Port, and (b) shall indemnify, defend, and hold the Port free and harmless from and against all claims, costs, damages, and expenses arising from or related to a breach by Contractor of the limitation set forth in this Section 15.2.

19.3 Port Security Guidelines. In accordance with applicable local and federal rules and regulations, Contractor and its employees or agents must pre-arrange their visits to Port property with a minimum of twenty-four (24) hours advance notice. Such notice shall include Contractor's employee's or agent's names, Social Security or Driver's license numbers, and the time, date, and nature of the anticipated visit. Contractor shall not have access to restricted areas without Port Police clearance or an authorized escort when required. If required, Contractor shall comply with all

applicable policies regarding issuance of Port visitor or identification cards. If required, Contractor shall obtain Transportation Workers Identification Credential (TWIC). If Contractor shall operate any vehicles on Port property, Contractor shall comply with all applicable policies regarding maintenance of insurance for vehicles, including submission of vehicle registration and proof of insurance for the vehicles.

20. DISCLOSURE. Contractor hereby represents that it has disclosed to the Port all matters regarding Contractor which if not disclosed to the Port would materially affect the Port's decision to enter into this Agreement with Contractor.

21. DISPOSITION OF PROPERTY AND MATERIALS; INTELLECTUAL PROPERTY RIGHTS

21.1 All plans, outlines, briefs, memoranda, studies, reports, analyses and all other work product and materials incidental or otherwise ("Work Product") which are produced by reason of this Agreement shall be and remain the property of the Port, regardless of whether Contractor is in possession of such Work Product, and may be used by the Port without permission from Contractor and without any additional costs to the Port.

21.2 All Work Products, including any and all intellectual property rights in said Work Product, arising out of this Agreement shall be the sole and exclusive property of the Port. Contractor explicitly acknowledges that the Port possesses exclusive rights to the Work Product arising out of this Agreement. Contractor shall not use or permit others to use in any way or form the Work Product without the express written consent of the Port.

22. EMPLOYMENT OF PERSONS CONVICTED OF A SEX OFFENSE.

§ 5253. Restriction Against Contractors Employing Convicted Sex Offenders from Working at Government of Guam Venues. (a) No person convicted of a sex offense under the provisions of Chapter 25 of Title 9 Guam Code Annotated, or an offense as defined in Article 2 of Chapter 28, Title 9 GCA in Guam, or an offense in any jurisdiction which includes, at a minimum, all of the elements of said offenses, or who is listed on the Sex Offender Registry, and who is employed by a business contracted to perform services for an agency or instrumentality of the government of Guam, shall work for his employer on the property of the government of Guam other than a public highway. (b) All contracts for services to agencies listed herein shall include the following provisions: (1) warranties that no person providing services on behalf of the contractor has been convicted of a sex offense under the provisions of Chapter 25 of Title 9 GCA or an offense as defined in Article 2 of Chapter 28, Title 9 GCA, or an offense in another jurisdiction with, at a minimum, the same elements as such offenses, or who is listed on the Sex Offender Registry; and (2) that if any person providing services on behalf of the contractor is convicted of a sex offense under the provisions of Chapter 25 of Title 9 GCA or an offense as defined in Article 2 of Chapter 28, Title 9 GCA or an offense in another jurisdiction with, at a minimum, the same elements as such offenses, or who is listed on the Sex Offender Registry, that such person will be immediately removed from working at said agency and that the administrator of said agency be informed of such within twenty-four (24) hours of such conviction. (c) Duties of the General Services Agency or Procurement

Administrators. All contracts, bids, or Requests for Proposals shall state all the conditions in § 5253(b). (d) Any contractor found in violation of § 5253(b), after notice from the contracting authority of such violation, shall, within twenty-four (24) hours, take corrective action and shall report such action to the contracting authority. Failure to take corrective action within the stipulated period may result in the temporary suspension of the contract at the discretion of the contracting authority.

23. MISCELLANEOUS

23.1 Waiver. No waiver by any party of any right on any occasion shall be construed as a bar to or waiver of any right or remedy on any future occasion.

23.2 Severability. If any provision of this Agreement shall be held or deemed by a court of competent jurisdiction to be invalid, inoperative or unenforceable, the remaining provisions herein contained shall nonetheless continue to be valid, operative and enforceable as though the invalid, inoperative or unenforceable provision had not been included in this Agreement.

23.10 Effect of Headings. The subject headings of the sections and subsections of this Agreement are included for purposes of convenience only and should not affect construction or interpretation of any of its provisions.

23.11 Counterparts. This Agreement may be executed in multiple counterparts, each of which shall be deemed to be an original and all of which, taken together, shall be deemed to be a single agreement.

23.12 Governing Law; Jurisdiction and Venue. This Agreement shall be governed by and construed in accordance with the laws of Guam. Each party consents to the jurisdiction of the courts of Guam for the purpose of construing or enforcing the rights and obligations created under this Agreement. The exclusive venue for all disputes that arise under this Agreement shall be the Superior Court in and for Guam.

23.13 Computation of Time. Whenever this Agreement provides for a time period of ten (10) days or less, weekends and Government of Guam holidays shall not be included in the computation. When this Agreement provides for a time period exceeding ten (10) days, weekends and Government of Guam holidays shall be included in the computation.

23.14 Remedies. Any dispute arising out of or under this Agreement shall be subject to the provisions of Chapter 9 (Legal and Contractual Remedies) of the Guam Procurement Regulations.

20.15 Signatures. This Agreement may be signed by the parties electronically, and in any number of counterparts, each of which shall be deemed an original, but all of which together shall constitute one and the same instrument. Delivery of an executed counterpart by one party to the other may be made by electronic transmission.

A single original with all original signatures is always best. In Guam (and other places) there are common law rules of evidence called the "best evidence rule" and the "parol evidence rule."

23.15 Guam Debarment. Bidder/Contractor warrants that it will comply with the provisions of 5 GCA Chapter 5 Articles 9 and 11, subject to debarment or suspension, and that it will not employ any subcontractors who have been federally debarred or debarred by the government of Guam.

23.16 Statutory Interest. Interest on amounts ultimately determined to be due to Bidder/Contractor or the government of Guam or the PAG shall be payable at the statutory rate applicable to judgments from the date the claim arose through the date of decision or judgment, whichever is later.

20.17 Variations in Quantity A. Variations Requiring Adjustments. Wherever the quantity of equipment or services covered under this solicitation or awarded contract is an estimated quantity and where the actual quantity of such equipment varies more than fifteen percent (15%) above or below the estimated quantity stated in the Contractor's Bid or this solicitation or any awarded contract, an adjustment in the contract price may be made upon demand of either party. The adjustment shall be based upon any increase or decrease in costs due solely to the variation above one hundred fifteen percent (115%) or below eighty-five percent (85%) of the estimated quantity. If the quantity variation is such as to cause an increase in the time necessary for completion of the contract, the Procurement Officer shall, upon receipt of a timely written request for an extension of time, prior to the date of final settlement of the contract, ascertain the facts and make such adjustment for extending the completion date as in the judgment of the Procurement Officer the findings justified.

B. Adjustments of Price. Any adjustment in contract price made pursuant to this clause shall be determined in accordance with the Price Adjustment Clause of this contract.

Guam has codified these rules:

(6 GCA § 1002) Guam Rules of Evidence, Rule 1002. Requirement of Original. (emphasis added)
To prove the content of a writing, recording, or photograph, the original writing, recording, or photograph is required, except as otherwise provided in these rules or by the laws of Guam.

6 GCA § 2107. Primary Evidence.
Primary Evidence is that kind of evidence which, under every possible circumstance, affords the greatest certainty of the fact in question. Thus, a written instrument is itself the best possible evidence of its existence and contents.

6 GCA § 2108. Secondary Evidence.
Secondary Evidence is that which is inferior to primary. Thus, a copy of an instrument or oral evidence of its contents is secondary evidence of the instrument and contents, provided that the copy is not introduced as an original as allowed by 1003 of this Title.

**** Approval Signatures will appear on following page ****

WITNESS WHEREOF, the parties have executed this Agreement on the date set forth below their respective signatures.

**JOSE D. LEON GUERRERO
COMMERCIAL PORT**

CONTRACTOR

RORY J. RESPICIO
General Manager

General Manager/President

Date: _____

Date: _____

APPROVED AS TO FORM:

**CERTIFICATION OF AVAILABILITY
OF FUNDS:**

JESSICA TOFT
Port Legal Counsel
Jose D. Leon Guerrero Commercial Port

JOSE B. GUEVARA III
Financial Affairs Controller
Jose D. Leon Guerrero Commercial Port

Date: _____

Date: _____

LABOR AND MATERIAL PAYMENT BOND

BOND NO. _____

KNOW ALL MEN BY THESE PRESENTS that _____ as Principal, hereinafter called the "Principal" and _____ a corporation duly organized under
(BONDING COMPANY)

the laws of the Territory of Guam, as Surety, hereinafter called "Surety", are held and firmly bound unto the **Port Authority of Guam, Jose D. Leon Guerrero Commercial Port** as Obligee, hereinafter called "Authority" for use and benefit of claimant as herein below defined, in the amount of _____ Dollars (\$ _____), for payment whereof the Principal and Surety bind themselves, their heirs, executors, administrators, successors and assigns, jointly and severally, firmly by these presents.

WHEREAS, the Principal has by written Agreement dated _____, 20____, Entered into a Contract with the Authority for the Project Titled:

IFB-PAG-CIP 024-003-WAREHOUSE 1 ROOF VENT REPLACEMENT PROJECT

in accordance with drawings and specifications prepared by the Authority, which contract is by reference made a part hereof, and is hereinafter referred to as the Contract.

NOW, THEREFORE, THE CONDITION OF THIS OBLIGATION is such that if the Principal shall promptly make payment to all claimants as hereinafter defined, for all labor and material used or reasonably required for use in the performance of the Contract, then this obligation shall be void; otherwise it shall remain in full force and effect, subject, however, to the following conditions:

1. A claimant is defined as one having a direct Contract with the Principal or with a subcontractor of the Principal for labor, material, or both, used or reasonably required for use in the performance of the contract, labor and material being construed to include that part of water, gas, power, light, heat, oil, gasoline, telephone service or rental of equipment directly applicable to the Contract.
2. The above-mentioned Principal and Surety hereby jointly and severally agree with the Authority that every claimant as herein defined, who has not been paid in full before the expiration of a period of ninety (90) days after the date on which the last of such claimant, may sue this Bond for the use of such claimant, prosecute the suit to final judgment for such sum or sums as may be justly due claimant, and have execute thereon. The Authority shall not be liable for the payment of any costs or expenses of any such suit.
3. No suit or action shall commence hereunder by any claimants:
 - a. Unless claimant, other than one having a direct Contract with the Principal, shall have given written notice to any two of the following: The Principal, the Authority, or the Surety above named, within ninety (90) days after such claimant did or performed the last of the work or labor, or furnished the last of the materials for which said claim is made, starting with substantial accuracy the amount claimed and the name of the party to whom the materials were furnished, or for whom the work or labor was done or performed. Such notice shall be served by mailing the same by registered mail or certified mail, postage prepaid, in an envelope addressed to the Principal, Authority or Surety, at any place where an office is

regularly maintained for the transaction of business, or serves in any manner in which legal process may be served in Guam in which the aforesaid project is located, save such service need not be made by public officer.

- b. After the expiration of one (1) year following the date on which the last of the labor was performed or material was supplied by the party bringing suit.
- c. Other than in court of competent jurisdiction for the county or district in which the construction contract was to be performed.

4. The amount of this bond shall be reduced by and to the extent of any payment or payments made in good faith hereunder, inclusive of the payment by Surety of mechanics' liens which may be filed of record against said improvement, whether or not claim for the amount of such lien be presented under and against this bond.

SIGNED AND SEALED this _____ day of _____, 20_____.

(WITNESS)

(PRINCIPAL)

(TITLE)

(SEAL)

(WITNESS)

(BONDING COMPANY)

(TITLE)

By: _____
(ATTORNEY-IN-FACT)

PERFORMANCE BOND

BOND NO. _____

KNOW ALL MEN BY THESE PRESENTS that _____ as Principal,
(Insert full name and address or legal title of Contractor)
hereinafter called Contractor and _____, a corporation duly organized
(Bonding Company)

under the laws of the Territory of Guam, hereinafter called Surety, are held and firmly bound unto the **Port Authority of Guam, Jose D. Leon Guerrero Commercial Port** as Obligee, herein after called the "Authority" for use and benefit of claimants as herein below defined, in the amount of _____ Dollars (\$_____), for the payment whereof Contractor and Surety bind themselves, their heirs, executors, administrators; successors and assigns, jointly and severally, firmly by these presents.

WHEREAS, the Contractor has by written Agreement dated _____, 20____, entered into a Contract with the Authority for the Project Titled:

IFB-PAG-CIP 024-003 WAREHOUSE 1 ROOF VENT REPLACEMENT PROJECT

in accordance with drawings and specifications prepared by the Authority which contract is by reference made a part hereof, and is hereinafter referred to as the Contract.

NOW, THEREFORE, THE CONDITION OF THIS OBLIGATION is such that, if the Contractor shall promptly and faithfully perform said contract then this obligation shall be null and void; otherwise it shall remain in full force and effect. The Surety hereby waives notice of any alteration or extension provided the same is within the scope of the contract. Whenever Contractor shall be and is declared by the Authority to be in default under the Contract, the Authority having performed territorial obligations thereunder, the Surety may promptly remedy the defaults or shall promptly;

1. Complete the Contract in accordance with its terms and conditions; or
2. Obtain a bid or bids for completing the Contract in accordance with its terms and conditions, and upon determination by the Authority and the Surety jointly of the lowest responsive, responsible Bidder, arrange for a Contract between such Bidder and the Authority, and make available as work progresses (even though there should be a default or a succession of defaults under the Contract or Contracts of completion arranged under this paragraph) sufficient funds to pay the cost of completion less the balance of the Contract Price; but not exceeding, including other costs and damages for which the Surety may be liable hereunder, the amount set forth in the first paragraph hereof. The term "balance of the contract price", as used in this paragraph shall mean the total amount payable by the Authority to Contractor under the Contract and any amendments thereto, less the amount properly paid by the Authority to Contractor. No right of action shall accrue on this bond to or for the use of any person or corporation other than the Authority or successors of the Authority.

SIGNED AND SEALED this _____ day of _____, 20_____.

(WITNESS)

(TITLE) (PRINCIPAL) (SEAL)

(WITNESS)

(BONDING COMPANY)

(TITLE) BY: _____
(ATTORNEY-IN-FACT)

VOLUME 5
SCOPE OF WORK, SPECIFICATIONS, BID SCHEDULE,
DRAWINGS AND PHOTOS

SCOPE OF WORK

WAREHOUSE 1 ROOF VENT REPLACEMENT PROJECT

A. PROJECT LOCATION

This project is located at Jose D. Leon Guerrero Commercial Port Warehouse 1 Building, Piti, Guam.

B. PROJECT DESCRIPTION

The Port Authority of Guam (PAG) is interested in soliciting an Invitation for Bid for the Warehouse 1 Roof Vent Replacement Project. Several roof vents were severely damaged or lost during Typhoon Mawar. Warehouse 1 has a total of fifteen (15) roof vent openings that are located at the center of each bay. Many of the roof vents are currently missing. This project will result in the replacement of all damaged and missing roof vents, to include the repair of the concrete curb the roof vents are mounted to. This project is funded in part by the Public Assistance (PA) Grant Program under the Federal Emergency Management Agency (FEMA) and is subject to the requirements stated in the grant award terms and conditions.

All work shall comply with applicable codes such as the International Building Code (IBC) 2009, Occupational Safety & Health Association (OSHA), National Electric Code (NEC), American Concrete Institute (ACI), American Society for Testing & Materials (ASTM), and the Underwriter Labor (UL).

C. PERIOD OF PERFORMANCE

The contractor has a total of one-hundred eighty-two (182) calendar days to complete this project. The POP shall include the time required to submit all necessary documentation, obtain Transportation Worker Identification Cards (TWIC), procurement of materials, and time required to complete the items identified in the scope of work.

D. GENERAL REQUIREMENTS

1. An official notice to proceed (NTP) will be issued to the contractor indicating the start of the period of performance. The PAG Engineering Division will coordinate a pre-construction meeting to ensure that all parties involved understand the contractors plan to execute the scope of work. The notice to proceed is normally issued at the pre-construction meeting. No work on-site may begin until after the NTP has been issued and the required documentation has been submitted.
2. Contractor to submit insurance coverage and bonding within seven (7) days of receiving an NTP;
3. The PAG requires a \$1,000,000 insurance policy for all projects. The insurance policy must include the following: General Liability Policy, Automobile Liability, Workers Compensation, and Employers Liability (Minimum Coverage is \$1,000,000). Insurance coverage must identify the Port Authority of Guam as Additional Insured;
4. All personnel assigned to this project are required to attend a Maritime Security (MARSEC) Brief. In general, PAG's Port Police Department conducts trainings on the 15th and 30th of each month. Contractor must submit a list of personnel prior to attending the MARSEC Brief;
5. The PAG Yard is a secured area. Contractors must obtain a Transportation Worker Identification Credential (TWIC) for personnel entering the PAG Container Yard. Alternatively, each TWIC holder can escort up to five (5) individuals. Individuals escorted must remain with their sponsor at all times;
6. The contractor must obtain a hot work permit prior to conducting any hot work that involves electric or gas welding, cutting, brazing, or similar flame or spark-producing operations. Hot work permits are issued by Port Police on a daily basis. The contractor should include the cost of obtaining the hot work permit when providing a quotation;
7. The contractor shall investigate the project sites, verify existing conditions and measurements prior to submitting bid cost proposals. Failure to do so shall not be a cause for additional claims against the PAG. In other words, all

bidding contractors must confirm quantities described below. Discrepancies in quantities post award will not be entertained;

8. The contractor shall provide all labor, materials, tools, and equipment required to complete the scope of work;
9. Contractor shall obtain any and all permits required for the job prior to the commencement site activities;
10. The contractor shall be responsible for the daily clean-up of project sites. Each day, all materials, tools, and equipment must be secured before close of business. All construction debris shall be disposed of at a designated government approved dumpsite at no cost to the PAG;
11. The contractor shall abide by OSHA regulations, provide safety warning signs, warning lights, and barricades as needed throughout the project. All workers shall have the necessary personal protective equipment (PPE) required to complete their job. Please note all personnel working along the wharves edge must wear a personal flotation device (PFD);
12. The contractor will provide an Environmental Protection Plan (EPP);
13. PAG Engineering and Safety Divisions shall conduct daily / random inspections throughout the life of project;
14. Submittals must be accompanied by a transmittal sheet and provide sufficient information to demonstrate that project standards / specifications will be met;
15. Prior to completing the project, the contractor must request for a pre-final and final inspection. This request must be made in writing with a minimum 48-hour notice;
16. Once the PAG has accepted all work completed, the contractor shall submit the final billing to the PAG along with the following documents associated with the project: As-built drawings, (hard and soft copy), Certificate of Completion, one-year Warranty Certificate, and Release of Liabilities;
17. Liquidated Damages (LD) may be applied for each day that the project exceeds the period of performance (POP). The amount shall be determined with the guidance of the PAGs Procurement Division.

E. SCOPE OF WORK:

1. Remove and dispose of loose debris located on the roof of Warehouse 1. The materials to be removed vary. The contractor is encouraged to visit the site prior to providing a bid. The debris to be removed includes but is not limited to the following: loose concrete, broken angle bars, various metal pieces, broken wires, etc. The work area needs to be free of tripping hazards and sharp objects that have the potential to fly, prior to removing any roof vents or starting concrete repairs. The disposal site must be GEPA approved disposal site. If required, the contractor shall provide proof of disposal (documentation, photos, receipts, etc.).
2. Dispose of all damaged / destroyed stainless steel roof vents. The contractor is responsible for providing the tools, equipment, and manpower needed to transport the stainless-steel roof vents from their current location to the disposal site. Note that the roof vents are damaged, but remain in one large piece. The contractor may need to have a crane or other equipment on site to safely remove the vents. In the event the contractor decides to cut the vents into smaller pieces for transport, a hot work permit must be obtained daily for any spark producing activity at the contractor's expense. A daily hot work permit can be obtained from the Port Police Division. The contractor is encouraged to incorporate permitting cost into their bid proposal. The disposal site must be GEPA approved disposal site. If required, the contractor shall provide proof of disposal (documentation, photos, receipts, etc.).
3. Provide a temporary wooden cover that allows air to flow in and out of the Warehouse bays. The cover must be durable enough to withstand the wind, rain, and be able to prevent a person from falling through the roof vent

opening. Once the contractor is ready to install the new stainless steel roof vents, the contractor must remove and dispose of the temporary covers at the contractor's expense.

4. Rebuild / repair each concrete curb surrounding the roof vent openings. The concrete curb around the roof vent opening sustained significant damage during Typhoon Mawar. The extent of the damage varies by location. Photos have been provided below for reference; however, the contractor is encouraged to inspect and measure the damages to the concrete curb prior to submitting a bid proposal.
5. The new stainless steel roof vents shall be mounted to the concrete curb and not directly into the concrete roof. The contractor must ensure the new roof vents are anchored to solid concrete that is not cracked, spalled, or delaminated. Thus, all new concrete repairs must be given sufficient time to cure before drilling, a concrete bonding agent must be used when pouring, the underlying rebar must be treated for rust, and all exposed rebar must be epoxy coated prior to pouring new concrete. In the event the existing rebar has lost more than 20% of its original diameter, that section shall be cut out and replaced. The concrete surface must be clean and free of dust, debris, and any foreign material, prior to pouring concrete.
6. The contractor should inspect the size of the reinforcing steel prior to submitting a bid. The rebar sizes observed within the concrete curb include but is not limited to #4, and #10.
7. When removing damaged or loose concrete, the contractor must saw cut a boundary around the area that will be repaired. This is required to minimize the chance of increasing the area of repair. This process will be monitored and inspected by the PAG Engineering Division representatives. When removing concrete, the depth of a repair shall be a minimum of a half-inch. Additional information on the concrete repair requirements have been provided below.
8. The contractor shall be required to coordinate inspections with the PAG Engineering Division point of contact (POC) for the project. All concrete repairs must be inspected by a PAG representative prior to pouring new concrete. The contractor must provide the following documentation prior to the inspection: attendance sheet, drawing indicating the location of repair, photos of the repair prior to pouring, and the dimensions/volume of the repair. In the event the preparation does not meet PAGs requirements, the contractor will need to make corrections prior to pouring and schedule a second inspection. All inspections must be requested in writing and a minimum of 24-hours in advance.
9. Although determining the exact quantity of concrete repair/crack repair that is needed may not be possible prior to bidding. The contractor must understand that a firm fixed price is required. The PAG will not consider requests for additional compensation related to the volume of concrete repair needed. In other words, the contractor must assume the risk when submitting a bid proposal in regard to estimating the amount of concrete repair that is needed. An estimated quantity has been provided for reference only and shall not be used to justify a change in price. Additionally, the extent of the area to be repaired is defined below. The contractor will have the opportunity to request for information (RFI) prior to submitting a bid proposal if needed.
10. Supply and install new 316 stainless steel roof vents. As this is a PA Grant funded project the roof vent shall be equivalent to the existing. Photos have been provided below for reference. The existing roof vent seem to be constructed of 1/16" stainless steel sheets which are welded to a stainless-steel angle bar frame. The angle bars appear to be 1-1/2" x 1-1/2" x 3/16" thick. Photos have been provided below for reference only. The contractor will need to verify the actual dimensions.
11. The roof vents were secured to the concrete curb with 1/2" stainless steel mushroom head spike anchors spaced between 4' and 5' apart. Quantities and dimensions need to be verified, however, there appears to be a total of fourteen (14) anchor bolts for each roof vent. Equivalent stainless-steel anchors are acceptable, but must be submitted to PAG for acceptance.

12. The contractor must be aware that the existing roof vents are not bolted or riveted together. All members are welded together and the contractor must provide documentation indicating that the roof vent was fabricated by a certified welder.
13. Additionally, the new roof vents will need to be lifted onto the roof and put in place with a crane. Welded lift points must be included on the new roof vents. The existing roof vents have four (4) welded lift points. Transporting the new vents onto the roof via forklift will not be allowed. The contractor will also not be allowed to carry the new roof vents across the roof with manpower. A crane must be used. Any damages that occur to the new roof vents during transport or installation will be corrected at the contractor's expense.
14. As Warehouse 1 is near Wharf F-3, any crane that will be utilized on the Southside of Warehouse 1 must remain a minimum of 25ft from the bulkhead and cannot exceed the Wharfs load capacity.
15. The new stainless steel roof vents must be constructed of NEW material. No material from the existing stainless steel roof vents shall be used in the fabrication of the new roof vents.
16. Contractor must ensure that the new stainless steel roof vents are constructed to withstand typhoon conditions. In other words, the new roof vents must be able to withstand wind speeds of up to 175 mph.

F. PROJECT DELIVERABLES

Contractors must provide two (2) copies and a soft copy of all project deliverables to the PAG Engineering Division. All submittals need to be accompanied by a transmittal sheet.

1. \$1,000,000 Project Insurance Policy. Certificate of Insurance must include the title of the project, project number, commercial general liability, automobile liability, umbrella liability, workers compensation and employer's liability, the PAG must be identified as the certificate holder, and the PAG must be named as additional insured.
2. Employees Listing (Indicating Employee Position and TWIC Cardholder Status)
3. Vehicle Listing (Indicating year make, model, color, license plate number). All company vehicles need to have the company logo.
4. Contractor Contact Information (Must include all essential personnel, owner, jobsite supervisor, safety office, etc.)
5. Submittal Register
6. Cost loaded Construction Schedule
7. Safety Plan / AHA
8. Material Submittals
 - a. Concrete repair material
 - b. Concrete bonding agent
 - c. Reinforcing steel
 - d. Rust converter
 - e. Epoxy paint for rebar coating
 - f. Anchoring epoxy (if needed for rebar replacement)
 - g. 316 Stainless steel roof vents
 - h. Stainless steel anchoring hardware. (Bolts, nuts, washer, lock-nut, etc.)
9. Monthly invoice accompanied by supporting documents. (Contractor production report, photos, materials receipts, transmittal sheets, etc.)

10. Weekly / Bi-weekly meeting agendas and meeting minutes
11. Attendance sheets (contractor must document attendance for meetings and inspections)
12. Inspection records (punch-list items, comments, time required for curing, etc.)
 - a. Contractor must coordinate preparatory and initial phase meetings prior to work activities.
 - b. Contractor must coordinate inspections prior to pouring new concrete. The PAG needs to have the opportunity to inspect the repair location prior to covering with concrete.
 - c. Contractor must coordinate an inspection of all repaired concrete locations prior to requesting for payment. Inspections should be scheduled once concrete has had sufficient time to cure.
13. Drawings
 - a. Contractor must identify and document the location and size of repairs made.
 - b. Roof Vent Drawings (dimensions, installation locations, etc.)
14. Closing-Documents
 - a. Certificate of Completion
 - b. 1-Year Warranty
 - c. Release of Lien
 - d. As-Built Drawings

***** Authorized Signatures Appear Below*****

Clarence V. Lagutang
CIP Manager

Jimmy Dacasin
Engineer II

Jerome C. Valdez
Engineer I

Jacob B Aquiningoc II
Engineer Technician II

G. BID SCHEDULE

	ITEM	QTY	UNIT	UNIT COST	EXTENDED COST
1.0	Dispose of debris on the roof of Warehouse 1. To include but not limited to broken concrete, old wires, broken angle bars, bolts, etc.	1	LS		
2.0	Dispose of all damaged / destroyed stainless steel roof vents.	1	LS		
3.0	Temporarily cover all roof vent openings with a durable wooden cover to protect the interior against rain and eliminate falling hazards.	12	EA		
4.0	Rebuild / repair concrete curb for each roof vent opening (Concrete spall repair, & crack repair) See scope of work for details and requirements.				
4.1	Concrete Curb – Bay 2	1	EA		
4.2	Concrete Curb – Bay 4	1	EA		
4.3	Concrete Curb – Bay 5	1	EA		
4.4	Concrete Curb – Bay 6	1	EA		
4.5	Concrete Curb – Bay 7	1	EA		
4.6	Concrete Curb – Bay 8	1	EA		
4.7	Concrete Curb – Bay 9	1	EA		
4.8	Concrete Curb – Bay 10	1	EA		
4.9	Concrete Curb – Bay 11	1	EA		
4.10	Concrete Curb – Bay 12	1	EA		
4.11	Concrete Curb – Bay 13	1	EA		
4.12	Concrete Curb – Bay 15	1	EA		
5.0	Supply and install new 316 stainless steel roof vent and mounting hardware.	12	EA		
6.0	Administrative	1	LS		
	GRAND TOTAL				

VACINITY MAP





Figure 1: Bay 1 – Roof vent to remain.



Figure 2: Bay 2 – Roof vent opening. Concrete curb to be repaired/rebuilt.



Figure 3: Bay 2 – Roof vent opening.

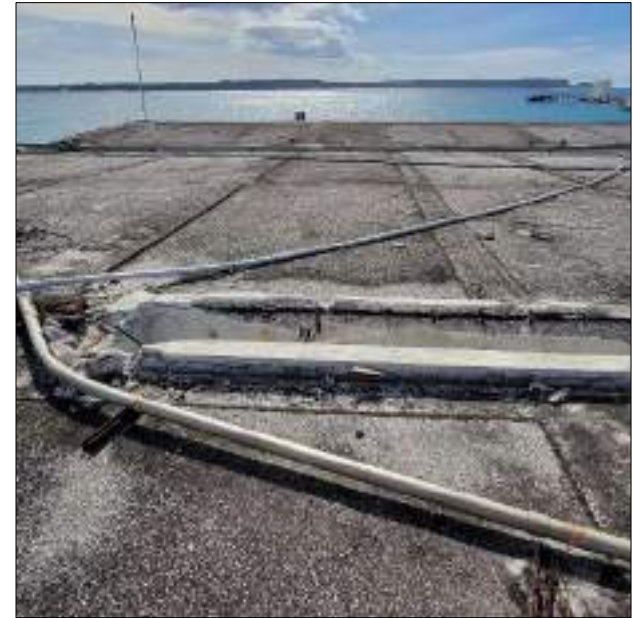


Figure 4: Bay 2 – Roof vent opening.



Figure 5: Bay 3 – Roof vent to remain.



Figure 6: Bay 4 – Roof vent opening. Concrete curb to be repaired /rebuilt.



Figure 7: Bay 4 – Roof vent opening.



Figure 8: Bay 5 – Roof vent to be disposed.



Figure 9: Bay 5 – Welds have failed and the vent has shifted.



Figure 10: Bay 5



Figure 11: Bay 5 – Concrete curb to be repaired.



Figure 12: Bay 6 – Concrete curb to be repair / rebuilt.



Figure 13: Bay 6



Figure 14: Bay 7 – Roof vent to be disposed.



Figure 15: Bay 7 –
Welds have failed and the roof vent is no longer connected to the concrete curb.



Figure 16: Bay 7 –
Concrete curb to be repaired/rebuilt.



Figure 17: Bay 8 – Roof vent to be disposed.



Figure 18: Bay 8 – Welds have failed and the vent is no longer connected to the concrete curb.



Figure 19: Bay 8 – Concrete curb to be repaired/rebuilt.



Figure 20: Bay 9 – Concrete curb to be repaired/rebuilt.



Figure 21: Bay 9



Figure 22: Bay 10 – Concrete curb to be repaired/rebuilt.



Figure 23: Bay 10



Figure 24: Bay 11 – Dispose of temporary cover.



**Figure 25: Bay 11 –
Concrete curb to be repaired/rebuilt.**



**Figure 26: Bay 12 –
Concrete curb to be repaired/rebuilt.**



Figure 27: Bay 12



**Figure 28: Bay 12 –
Stainless steel sheets to be disposed.**



**Figure 29: Bay 13 –
Concrete curb to be repaired/rebuilt.**



Figure 30: Bay 13



**Figure 31: Bay 13 –
Stainless steel sheets to be disposed**



**Figure 32: Bay 14 –
Roof vent to remain.**



**Figure 33: Bay 15 –
Concrete curb to be repaired/rebuilt.**



Figure 34: Bay 15



**Figure 35: Bay 15 – Concrete curb to be repaired.
Concrete curb has a height of 31" from top to bottom.**



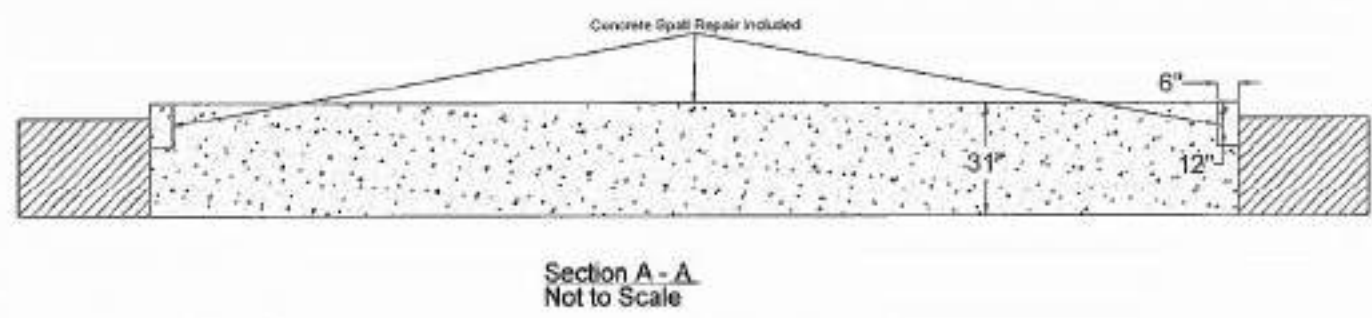
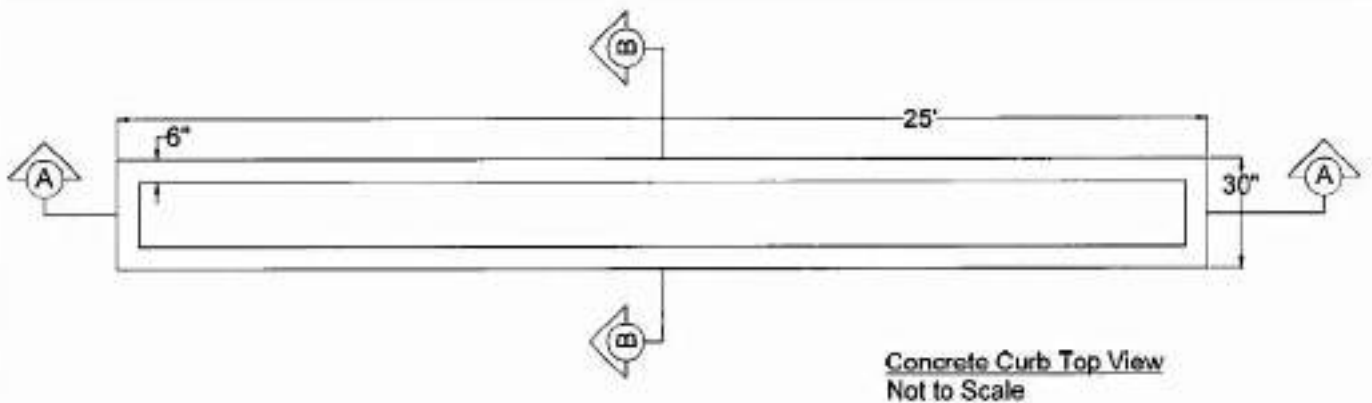
Figure 36: Near Bay 12 & 13 – Roof vent to be disposed.

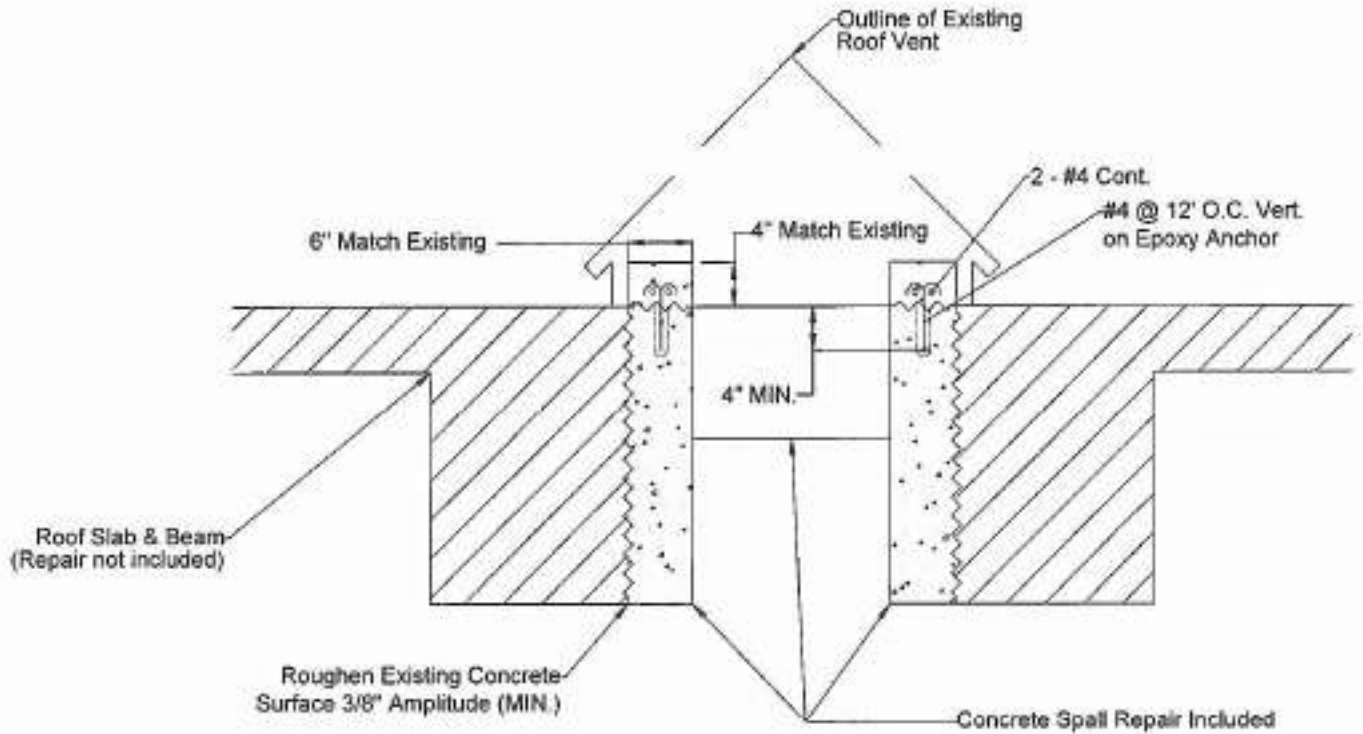


Figure 37: Near Bay 3 & 4 – Roof vent to be disposed.



Figure 38: Example of roof vent leg and anchor.





Section B - B
Not to Scale

LEGEND/SCOPE OF WORK

ITEM	SYMBOL	DESCRIPTION	UNIT	QUANTITY	REMARKS
1		REMOVE EXISTING	LS	-	
2		REINFORCEMENT	LS	-	
3		CONCRETE	CU	-	
4		FORMWORK	SF	-	
5		REINFORCING BARS	LB	-	
6		CONCRETE FINISH	SF	-	
7		FORMWORK	SF	-	
8		REINFORCING BARS	LB	-	
9		CONCRETE	CU	-	
10		FORMWORK	SF	-	
11		REINFORCING BARS	LB	-	
12		CONCRETE	CU	-	
13		FORMWORK	SF	-	
14		REINFORCING BARS	LB	-	
15		CONCRETE	CU	-	
16		FORMWORK	SF	-	
17		REINFORCING BARS	LB	-	
18		CONCRETE	CU	-	
19		FORMWORK	SF	-	
20		REINFORCING BARS	LB	-	
21		CONCRETE	CU	-	
22		FORMWORK	SF	-	
23		REINFORCING BARS	LB	-	
24		CONCRETE	CU	-	
25		FORMWORK	SF	-	
26		REINFORCING BARS	LB	-	
27		CONCRETE	CU	-	
28		FORMWORK	SF	-	
29		REINFORCING BARS	LB	-	
30		CONCRETE	CU	-	
31		FORMWORK	SF	-	
32		REINFORCING BARS	LB	-	
33		CONCRETE	CU	-	
34		FORMWORK	SF	-	
35		REINFORCING BARS	LB	-	
36		CONCRETE	CU	-	
37		FORMWORK	SF	-	
38		REINFORCING BARS	LB	-	
39		CONCRETE	CU	-	
40		FORMWORK	SF	-	
41		REINFORCING BARS	LB	-	
42		CONCRETE	CU	-	
43		FORMWORK	SF	-	
44		REINFORCING BARS	LB	-	
45		CONCRETE	CU	-	
46		FORMWORK	SF	-	
47		REINFORCING BARS	LB	-	
48		CONCRETE	CU	-	
49		FORMWORK	SF	-	
50		REINFORCING BARS	LB	-	
51		CONCRETE	CU	-	
52		FORMWORK	SF	-	
53		REINFORCING BARS	LB	-	
54		CONCRETE	CU	-	
55		FORMWORK	SF	-	
56		REINFORCING BARS	LB	-	
57		CONCRETE	CU	-	
58		FORMWORK	SF	-	
59		REINFORCING BARS	LB	-	
60		CONCRETE	CU	-	
61		FORMWORK	SF	-	
62		REINFORCING BARS	LB	-	
63		CONCRETE	CU	-	
64		FORMWORK	SF	-	
65		REINFORCING BARS	LB	-	
66		CONCRETE	CU	-	
67		FORMWORK	SF	-	
68		REINFORCING BARS	LB	-	
69		CONCRETE	CU	-	
70		FORMWORK	SF	-	
71		REINFORCING BARS	LB	-	
72		CONCRETE	CU	-	
73		FORMWORK	SF	-	
74		REINFORCING BARS	LB	-	
75		CONCRETE	CU	-	
76		FORMWORK	SF	-	
77		REINFORCING BARS	LB	-	
78		CONCRETE	CU	-	
79		FORMWORK	SF	-	
80		REINFORCING BARS	LB	-	
81		CONCRETE	CU	-	
82		FORMWORK	SF	-	
83		REINFORCING BARS	LB	-	
84		CONCRETE	CU	-	
85		FORMWORK	SF	-	
86		REINFORCING BARS	LB	-	
87		CONCRETE	CU	-	
88		FORMWORK	SF	-	
89		REINFORCING BARS	LB	-	
90		CONCRETE	CU	-	
91		FORMWORK	SF	-	
92		REINFORCING BARS	LB	-	
93		CONCRETE	CU	-	
94		FORMWORK	SF	-	
95		REINFORCING BARS	LB	-	
96		CONCRETE	CU	-	
97		FORMWORK	SF	-	
98		REINFORCING BARS	LB	-	
99		CONCRETE	CU	-	
100		FORMWORK	SF	-	

EMBEDMENT AND LAP NOTES

1. PROVIDE EMBEDMENT AND LAP DETAILS AS SHOWN ON THIS SHEET AND AS NOTED ON THE DRAWINGS.

2. THE BARS ARE TO BE LAP JOINTED IN ACCORDANCE WITH THE NOTES ON THIS SHEET AND THE DRAWINGS.

PRIMARY REINFORCING TYPICAL BENDS

BAR SIZE	180°	90°	45°	30°
1/2"	1.5"	1.5"	1.5"	1.5"
3/8"	1.5"	1.5"	1.5"	1.5"
1/4"	1.5"	1.5"	1.5"	1.5"
3/16"	1.5"	1.5"	1.5"	1.5"
1/8"	1.5"	1.5"	1.5"	1.5"

TYP HOOPS AND CROSS-TIES DETAIL

BAR SIZE	180°	90°	45°	30°
1/2"	1.5"	1.5"	1.5"	1.5"
3/8"	1.5"	1.5"	1.5"	1.5"
1/4"	1.5"	1.5"	1.5"	1.5"
3/16"	1.5"	1.5"	1.5"	1.5"
1/8"	1.5"	1.5"	1.5"	1.5"

STRUCTURAL DESIGN CRITERIA

1. DESIGN OF REINFORCED CONCRETE SHALL BE IN ACCORDANCE WITH THE FOLLOWING:

2. DESIGN OF REINFORCED CONCRETE SHALL BE IN ACCORDANCE WITH THE FOLLOWING:

3. DESIGN OF REINFORCED CONCRETE SHALL BE IN ACCORDANCE WITH THE FOLLOWING:

GENERAL NOTES

1. ALL WORK SHALL BE IN ACCORDANCE WITH THE SPECIFICATIONS AND REQUIREMENTS OF THE CONTRACT DOCUMENTS.

2. THE CONTRACTOR SHALL BE RESPONSIBLE FOR OBTAINING ALL NECESSARY PERMITS AND APPROVALS FROM THE APPROPRIATE AGENCIES.

3. THE CONTRACTOR SHALL BE RESPONSIBLE FOR PROTECTING ALL EXISTING UTILITIES AND STRUCTURES.

4. THE CONTRACTOR SHALL BE RESPONSIBLE FOR MAINTAINING ACCESS TO ALL ADJACENT PROPERTIES.

5. THE CONTRACTOR SHALL BE RESPONSIBLE FOR THE PROTECTION OF ALL EXISTING CURBS AND SIDEWALKS.

6. THE CONTRACTOR SHALL BE RESPONSIBLE FOR THE PROTECTION OF ALL EXISTING LANDSCAPING AND PLANTING.

7. THE CONTRACTOR SHALL BE RESPONSIBLE FOR THE PROTECTION OF ALL EXISTING PAVEMENT AND SURFACING.

8. THE CONTRACTOR SHALL BE RESPONSIBLE FOR THE PROTECTION OF ALL EXISTING UTILITIES AND STRUCTURES.

9. THE CONTRACTOR SHALL BE RESPONSIBLE FOR THE PROTECTION OF ALL EXISTING CURBS AND SIDEWALKS.

10. THE CONTRACTOR SHALL BE RESPONSIBLE FOR THE PROTECTION OF ALL EXISTING LANDSCAPING AND PLANTING.

11. THE CONTRACTOR SHALL BE RESPONSIBLE FOR THE PROTECTION OF ALL EXISTING PAVEMENT AND SURFACING.

12. THE CONTRACTOR SHALL BE RESPONSIBLE FOR THE PROTECTION OF ALL EXISTING UTILITIES AND STRUCTURES.

13. THE CONTRACTOR SHALL BE RESPONSIBLE FOR THE PROTECTION OF ALL EXISTING CURBS AND SIDEWALKS.

14. THE CONTRACTOR SHALL BE RESPONSIBLE FOR THE PROTECTION OF ALL EXISTING LANDSCAPING AND PLANTING.

15. THE CONTRACTOR SHALL BE RESPONSIBLE FOR THE PROTECTION OF ALL EXISTING PAVEMENT AND SURFACING.

16. THE CONTRACTOR SHALL BE RESPONSIBLE FOR THE PROTECTION OF ALL EXISTING UTILITIES AND STRUCTURES.

17. THE CONTRACTOR SHALL BE RESPONSIBLE FOR THE PROTECTION OF ALL EXISTING CURBS AND SIDEWALKS.

18. THE CONTRACTOR SHALL BE RESPONSIBLE FOR THE PROTECTION OF ALL EXISTING LANDSCAPING AND PLANTING.

19. THE CONTRACTOR SHALL BE RESPONSIBLE FOR THE PROTECTION OF ALL EXISTING PAVEMENT AND SURFACING.

20. THE CONTRACTOR SHALL BE RESPONSIBLE FOR THE PROTECTION OF ALL EXISTING UTILITIES AND STRUCTURES.

REINFORCING BARS

1. ALL REINFORCING BARS SHALL BE IN ACCORDANCE WITH THE FOLLOWING:

2. ALL REINFORCING BARS SHALL BE IN ACCORDANCE WITH THE FOLLOWING:

3. ALL REINFORCING BARS SHALL BE IN ACCORDANCE WITH THE FOLLOWING:

PERMITS DIVISION OF THE CITY OF LOS ANGELES

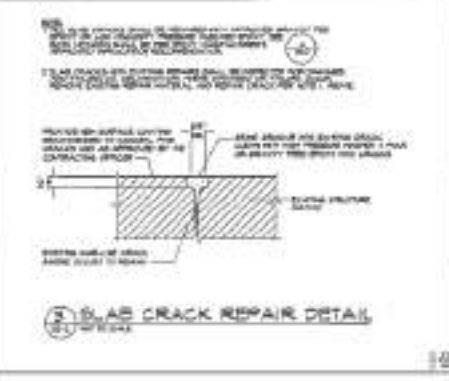
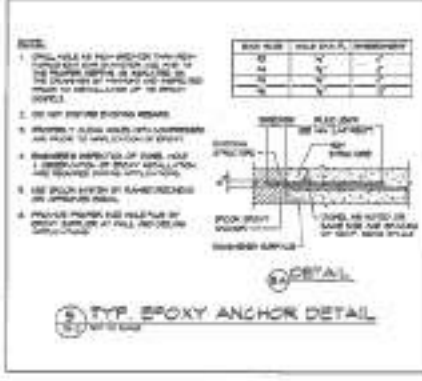
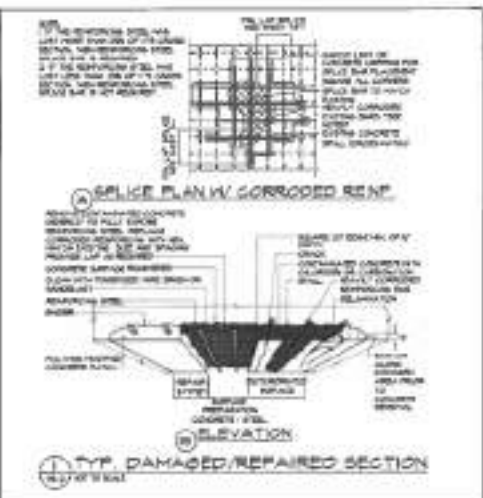
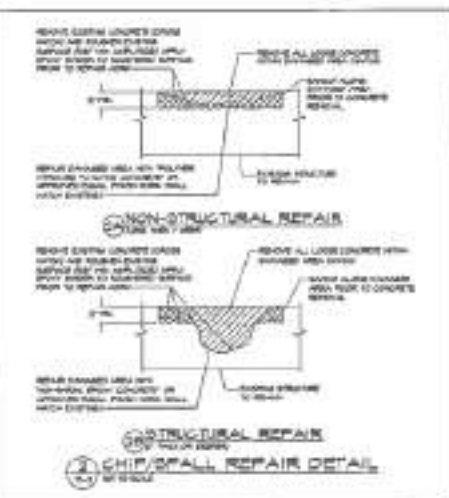
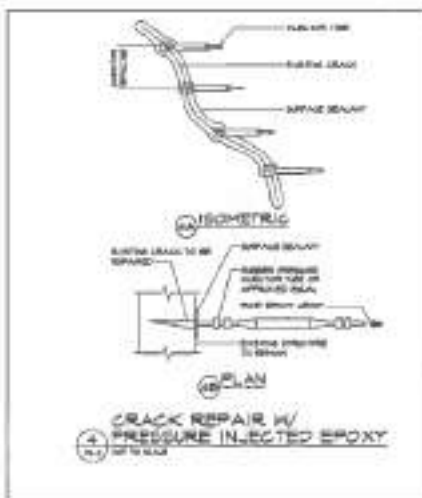
REVISION: 11/1/2018

PROJECT: 18-1

DATE: 11/1/2018

BY: [Signature]

FOR: [Signature]



REVISIONS

NO.	DATE	DESCRIPTION
1	11/1/2018	ISSUED FOR PERMITS
2	11/1/2018	REVISIONS

PERMITS DIVISION OF THE CITY OF LOS ANGELES

REVISION: 11/1/2018

PROJECT: 18-2

DATE: 11/1/2018

BY: [Signature]

FOR: [Signature]